



OPERATIONS - PARTS MANUAL



AT14S Track Buggy

allen
ENGINEERING
CORPORATION
819 South 5th Street
Paragould, AR 72450

***For your own safety and protection from personal injury, carefully read, understand, and observe the safety instructions described in this manual.
Keep this manual or a copy of it with the machine at all times.***

AT14S Track Buggy

OPERATIONS - PARTS

MANUAL

This manual covers the products listed below:

<u>Part No.</u>	<u>Description</u>
065000	BUGGY, 14CF POLY

Copyright © 2016 Allen Engineering Corporation
All rights reserved

All information, specifications, and illustrations in this manual are subject to change without notice and are based on the latest information at the time of publication. No part of this manual may be reproduced or transmitted in any form or by any means, electronic or mechanical, for any purpose, without the express written permission of Allen Engineering Corporation (AEC). AEC assumes no responsibility or liability for any errors or inaccuracies that may appear in this manual.

Allen Products are covered under one or more of the following patent numbers:

U.S. Design Patents: 344,736; 400,542; 400,544; 402,998; 402,999; 403,332; 404,041; 404,042; 410,931; 413,127; 416,564; 465,897; 466,909; 474,203.

U.S. Utility Patents: 5,108,220; 5,238,323; 5,328,295; 5,352,063; 5,405,216; 5,476,342; 5,480,257; 5,480,258; 5,533,831; 5,562,361; 5,567,075; 5,613,801; 5,658,089; 5,685,667; 5,803,658; 5,816,739; 5,816,740; 5,890,833; 5,934,823; 5,967,696; 5,988,938; 5,988,939; 6,019,433; 6,019,545; 6,048,130; 6,053,660; 6,089,786; 6,106,193; 6,857,815; 5,288,166; 6,582,153 B1, 7,108,449; 7,114,876; 7,316,523; 7,690,864 B2

Canadian Patents: 2,039,893.

First Issue: September 2016

Printed in U.S.A.

Limited Warranty

Allen Engineering Corporation ("Allen") warrants its products to be free of defects in material or workmanship for:

TWO YEARS FROM END USER'S DATE OF PURCHASE

Warranty period begins on the date of purchase by the End User of the product. All warranty is based on the following limited warranty terms and conditions, including the disclaimer of implied warranties and consequential damages.

1. Allen's obligation and liability under this warranty is limited to repairing or replacing parts if, after Allen's inspection, there is determined to be a defect in material or workmanship. Allen reserves the choice to repair or replace.
2. If Allen chooses to replace the part, it will be at no cost to the customer and will be made available to the Allen Distributor, Dealer, or Rental Center from whom the End User purchased the product.
3. Replacement or repair parts, installed in the product, are warranted only for the remainder of warranty period of the product as though they were the original parts.
4. Allen does not warranty engines or batteries. Engine warranty claims should be made directly to an authorized factory service center for the particular engine manufacturer. Batteries are not warranted due to unknown treatment during transport, etc, and any battery claims should be directed to the battery manufacturer.
5. Allen's warranty does not cover the normal maintenance of products or its components (such as engine tuneups and oil & filter changes). The warranty also does not cover normal wear and tear items (such as belts and consumables).
6. Allen's warranty will be void if it is determined that the defect resulted from operator abuse, failure to perform normal maintenance on the product, modification to product, alterations or repairs made to the product without the written approval of Allen. Allen specifically excludes from warranty any damage to any trowels resulting from an impact to the rotors.
7. Impact damage to gear boxes is not covered under the Allen warranty and is deemed customer abuse.
8. Allen will pay shop labor on warranty items at the Allen Shop Labor Rate in existence on the date of the warranty claim. An Allen labor chart will determine the time allowed to complete a repair and will govern the shop labor hours that will be allowed.
9. Allen will pay freight on warranty replacement parts at worldwide standard ground rates. No warranty replacement parts will be shipped air freight at the expense of Allen. Allen only pays outbound freight charges when sending warranty replacement parts to the customer via ground service. Allen does not pay any inbound freight. However, if Allen determines this to be a warranted item, only then will Allen reimburse the customer for inbound freight at standard ground rates.
10. ALLEN ENGINEERING CORPORATION'S WARRANTY POLICY WILL NOT COVER THE FOLLOWING: TAXES; SHOP SUPPLIES; ENVIRONMENTAL SURCHARGES; AIR FREIGHT; TRAVEL TIME; LOSS OF TIME; INCONVENIENCE; LOSS OF RENTAL REVENUE; RENTAL COSTS OF EQUIPMENT USED TO REPLACE THE PRODUCT BEING REPAIRED; LOSS OF USE OF THE PRODUCT; COMMERCIAL LOSS; OR ANY OTHER CHARGES WHATSOEVER OR ANY LIABILITIES FOR DIRECT, INCIDENTAL, OR CONSEQUENTIAL DAMAGE OR DELAY.
11. ALLEN ENGINEERING CORPORATION MAKES NO OTHER WARRANTY, EXPRESSED OR IMPLIED. THIS LIMITED WARRANTY IS IN LIEU OF THE WARRANTY OF MERCHANTABILITY AND FITNESS. THERE ARE NO OTHER WARRANTIES THAT EXTEND BEYOND THE DESCRIPTION ON THIS DOCUMENT.
12. No Allen employee or representative is authorized to change this warranty in any way or grant any other warranty unless such change is made in writing and signed by an officer of Allen Engineering Corporation.

Table of Contents

Title	Page
Limited Warranty	4
Table of Contents	5
Information Contained In This Manual	7
Dealer Information	8
Ordering Parts	9
Model Number - Serial Number Codes	10
Unit Identification	11
Technical specifications	12
Dimensions	13
Engine Specifications	14
Engine Serial Number Information	15
Section 1 - Safety	
State Regulations	16
Federal Regulations	17
Safety Information	18
General Safety	20
Transportation and Lifting Safety	26
Safety Retainer Positioning	28
Section 2 - Operations	
Driving Position Controls	29
General Operating Instructions	30
General Operations	32
Section 3 - Service	
Grease Points	34
Track Tightening	39
Hydraulic Oil Intake Filter	40
Air Filter	41
Wheel Gear Maintenance	42
Maintenance Schedule	44
Hydrostatic Transmission System	45
Pump Maintenance	46
Transmission Pressures	48
Hydraulic System Service Pressures	50
Electrical System	51
Troubleshooting	53

Table of Contents - Continued

Title	Page
Parts	
Framework Assembly	54
Hydraulic Tank Assembly	56
Engine Assembly	58
Hydraulic Pump Assembly	60
Hydraulic Cooler Assembly	62
Fuel Tank Assembly	64
Wiring Assembly	66
Operator Console Assembly	68
Throttle Assembly	70
Control Lever Assembly	72
Block Drainages and Servos	76
Hood Assembly	78
Bucket Valve Fitting Assembly	80
Hydraulic Hose Assembly	82
Decals	84
Maintenance Tools	88
Hourmeter	90
Bucket Hydraulic Cylinder Assembly	92
Swivel Hydraulic Cylinder Assembly	94
Trilateral Tipping Bucket Assembly	96
Hydraulic Schematic	102
Electrical Schematic	104

Information Contained in this Manual



This manual provides information and procedures to safely operate and maintain the Allen Machine.

For your own safety and protection from personal injury, carefully read, understand, and observe the safety instructions described in this manual. Keep this manual or a copy of it with the machine at all times.

Always operate this machine in accordance with the instructions described in this manual. A well maintained piece of equipment will provide many years of trouble free operation.

This manual is divided into the following sections:

**SECTION 1
SAFETY**

**SECTION 2
OPERATIONS**

**SECTION 3
SERVICE**

**SECTION 4
PARTS**

Complete any warranty requirements as specified by the engine manufacturer in their instructions found inside the manual box located on the operator's control panel.

Your engine is not manufactured by Allen Engineering Corporation, Inc, and therefore is not covered under Allen Engineering Corporation, Inc warranty.

Your engine manufacturer should be contacted if you wish to purchase a parts manual or a repair manual for your engine.

Refer to enclosed owners engine manual for complete O&M instructions. See your battery manufacturer for battery warranty.

Dealer Information

Your Dealer has Allen Engineering Corporation trained mechanics and original Allen replacement parts. Always contact the Allen Dealer who sold you this machine for Allen Certified repairs and replacement parts.

Place Allen Dealer information below for future reference.

Dealer Name: _____

Phone #: (____) - ____ - _____

Address: _____

City: _____ State: _____ Zip: _____

Salesman: _____ Mobile Phone _____

Additional Comments: _____



Ordering Parts

Section 4 contains illustrated parts lists for help in ordering replacement parts for your machine. Follow the instructions below when ordering parts to insure prompt and accurate delivery:

1. All orders for service parts - include the serial number for the machine. Shipment will be delayed if this information is not available.
2. Include correct description and part number from the "PARTS" section of this manual.
3. Specify exact shipping instructions, including the preferred routing and complete destination address.
4. DO NOT return parts to AEC without receiving written authorization from AEC. All authorized returns must be shipped pre-paid.
5. When placing an order, please contact the AEC dealer nearest you.



All information, specifications, and illustrations in this manual are subject to change without notice and are based on the latest information at the time of publication.

VISIT US!!!



www.alleneng.com

LIKE US!!!



www.facebook.com/AllenEngineering

FOLLOW US!!!



[@alleneng](https://twitter.com/alleneng)

WATCH US!!!



www.youtube.com/AllenMachinery

Model Number - Serial Number Codes

Manufacturer's Codes:

When ordering parts or requesting service information, you will always be asked to specify the model and serial numbers of the machine. The legends below specifically defines each significant character or group of characters of the Model Number and Serial Number codes.

Model Number

AT14 S

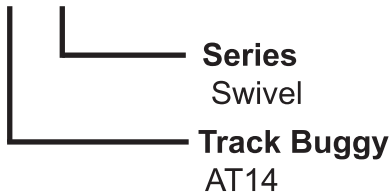

Serial Number

The serial number found on the identification plate is a ten digit format. The model number identifies your machine and will ensure that you receive the correct replacement parts.

Serial Number Example:

T14 10 16 001

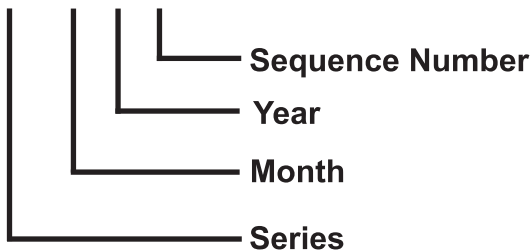

Unit Identification

Unit Identification Plate Location:

An identification plate listing the model number and the serial number is attached to each unit and is located on the lower inside face of the console. See image below for serial number plate location. This plate should not be removed at any time.

Please record the information found on this plate below so it will be available should the identification plate become lost or damaged. When ordering parts or requesting service information, you will always be asked to specify the model and serial numbers of the machine.

FILL IN FOR FUTURE REFERENCE

Model Number: _____

Serial Number: _____

Date Purchased: _____

Purchased From: _____



Technical Specifications

Operating weight (without operator)	Kg	795
	lbs	1,753
Operating capacity	Kg	1000
	lbs	2,205
Load capacity: - heaped (SAE Standard)	m ³	0.58
	ft ³	20.4
- flat: sand	m ³	0.48
	ft ³	16.9
liquid	m ³	0.4
	ft ³	14.1
ENGINE		
Petrol Engine		HONDA GX630
Maximum engine rotation speed	rpm	3600
Max. power at maximum speed	HP/Kw	20.8 / 15.5
Displacement	cm ³	688
Cylinders	n°	2
Max. torque at 2500 rpm	daNm	4.8
Cooling		Air-Cooled
Transmission		Hydrostatic
Transmission pumps with variable displacement pistons	n°	2
Total capacity	l/min.	29x2
Services gear pump	n°	1
Capacity	l/min.	7
Max. operating pressure for driving	bar	230
Max. operating pressure for services	bar	160
Maximum speed:	Km/h	4.5 / 9.0
	mph	2.8 / 5.6
Separate track steering system		Hydrostatic
Rubber track tensioning		spring + adjusting screw
Width of the rubber track	mm	180
	in	7.08"
Specific ground pressure: - empty/loaded	Kg/cm ²	-
Max. gradient when fully loaded	max %	-
REFUELLING		
Fuel tank capacity	lt	9
	gal	2.37
Hydraulic oil tank capacity	lt	18
	gal	4.75
Pumps overload pressure	bar	20 – 22
Noise emission level at 3000 rpm	dBA	101

Dimensional Specifications

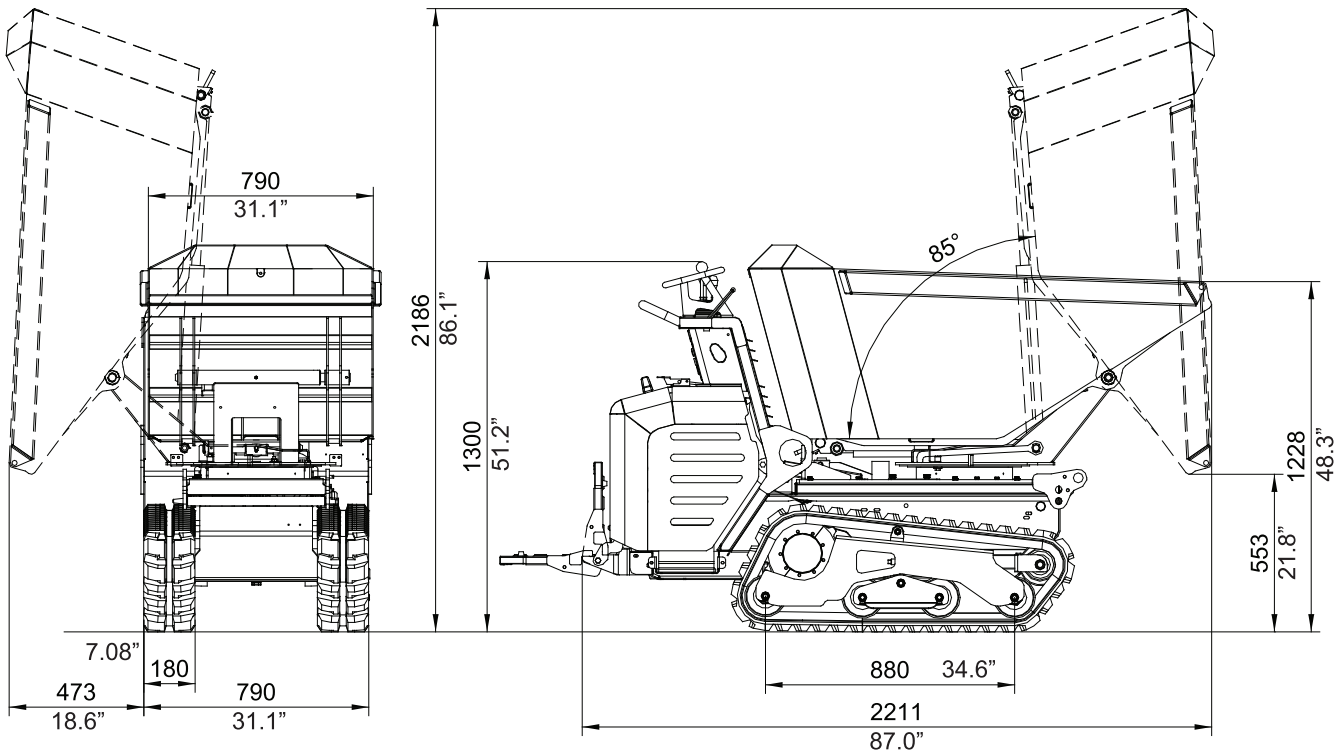

Engine Specifications

Engine Type	Air-cooled 4-stroke OHV
Bore x Stroke	78 X 72 mm
Displacement	688 cm ³
Net Power Output*	20.8 hp (15.5 kW) @ 3,600 rpm
Net Torque	35.6 lbs ft (48.3 Nm) @ 2,500 rpm
PTO Shaft Rotation	Counterclockwise (from PTO shaft side)
Compression Ratio	9.3:1
Lamp/Charge coil options	2.7A, 17A, 26A
Carburetor	Horizontal type, two barrel butterfly valve, internal vent
Ignition System	Digital CDI with variable ignition timing
Starting System	Electric
Lubrication System	Forced lubrication
Governor System	Mechanical
Air cleaner	Dual element
Oil Capacity	2.1 US qt (2.0l)
Fuel	Unleaded 86 octane or higher
Dry Weight	96.8 lb (44 kg)



Engine Serial Number Information

Record the engine serial number, type and purchase date in the spaces below. You will need this information when ordering parts and when making technical and warranty inquiries.

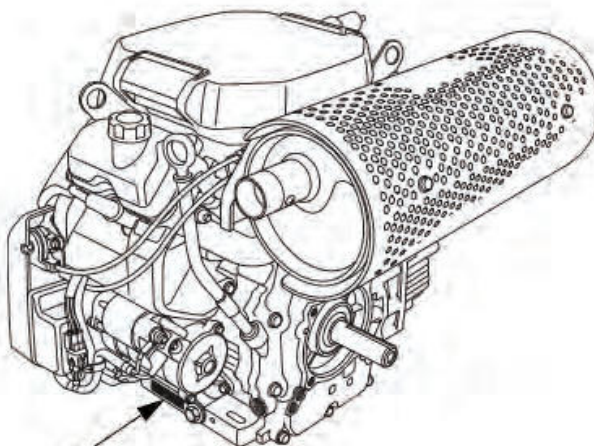



**SERIAL NUMBER &
ENGINE TYPE LOCATION**

Engine serial number: _____

Engine type: _____

Date Purchased: ____ / ____ / ____

 **WARNING** 

CALIFORNIA — Proposition 65 Warning

Engine exhaust and some of its constituents, and some dust created by power sanding, sawing, grinding, drilling and other construction activities contains chemicals known to the State of California to cause cancer, birth defects and other reproductive harm. Some examples of these chemicals are:

- Lead from lead-based paints.
- Crystalline silica from bricks.
- Cement and other masonry products.
- Arsenic and chromium from chemically treated lumber.

Your risk from these exposures varies, depending on how often you do this type of work. To reduce your exposure to these chemicals: **ALWAYS** work in a well ventilated area, and work with approved safety equipment, such as dust masks that are specially designed to filter out microscopic particles.

Federal Regulations Respiratory Hazards

SECTION 1 SAFETY

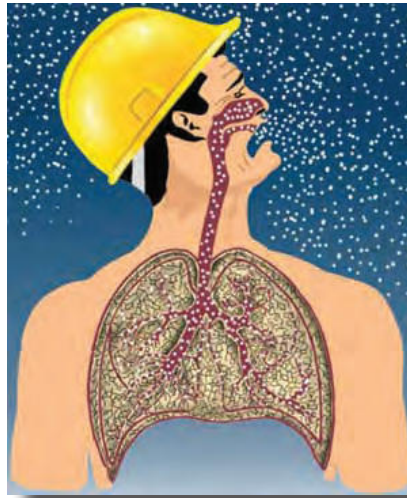

⚠️ WARNING

RESPIRATORY HAZARDS

Grinding/cutting/drilling of masonry, concrete, metal and other materials can generate dust, mists and fumes containing chemicals known to cause serious or fatal injury or illness, such as respiratory disease, cancer, birth defects or other reproductive harm. If you are unfamiliar with the risks associated with the particular process and/or material being cut or the composition of the tool being used, review the material safety data sheet and/or consult your employer, the material manufacturer/supplier, governmental agencies such as OSHA and NIOSH and other sources on hazardous materials. California and some other authorities, for instance, have published lists of substances known to cause cancer, reproductive toxicity, or other harmful effects.

Control dust, mist and fumes at the source where possible. In this regard use good work practices and follow the recommendations of the manufacturers or suppliers, OSHA/NIOSH, and occupational and trade associations. Water should be used for dust suppression when wet cutting is feasible. When the hazards from inhalation of dust, mists and fumes cannot be eliminated, the operator and any bystanders should always wear a respirator approved by NIOSH/MSHA for the materials being used.

⚠️ WARNING

SILICOSIS WARNING

Grinding/cutting/drilling of masonry, concrete, metal and other materials with silica in their composition may give off dust or mists containing crystalline silica. Silica is a basic component of sand, quartz, brick clay, granite and numerous other minerals and rocks. Repeated and/or substantial inhalation of airborne crystalline silica can cause serious or fatal respiratory diseases, including silicosis. In addition, California and some other authorities have listed respirable crystalline silica as a substance known to cause cancer. When cutting such materials, always follow the respiratory precautions mentioned above.

SECTION 1 SAFETY

Safety Information

Do not operate or service the equipment before reading the entire manual. Safety precautions should be followed at all times when operating this equipment. Failure to read and understand the safety messages and operating instructions could result in injury to yourself and others.

SAFETY NOTES

The four safety notes shown below will inform you about potential hazards that could injure you or others. The safety notes specifically address the level of exposure to the operator and are preceded by one of four words: DANGER, WARNING, CAUTION or NOTICE.



Indicates a hazardous situation which, if not avoided, **will** result in death or serious injury.



Indicates a hazardous situation which, if not avoided, **could** result in death or serious injury.









Indicates a hazardous situation which, if not avoided, could result in minor or moderate injury.



Addresses practices not related to personal injury.



Potential hazards associated with the operation of this equipment will be referenced with hazard symbols which may appear throughout this manual in conjunction with safety notes.

Symbol	Safety Hazard
	Lethal exhaust gas hazards
	Explosive fuel hazards
	Burn hazards
	Rotating parts/crush hazards
	Pressurized fluid hazards
	Hydraulic fluid hazards

SECTION 1 SAFETY

General Safety

For the vehicle to work properly it must be set up perfectly (installation and use) and the oil level of the various mechanisms must be verified. An inaccurate inspection or incorrect installation or improper use can impair the vehicle efficiency and compromise operator safety.

All the information and diagrams in this manual refer to the model in production at the time of publication.

For more information contact an Authorized Service Center.

Allen Engineering Corporation reserves the right to make changes without prior notification.

Everything in this manual belongs to the AEC, therefore no part or diagram can be used for any other use without authorization.

Caution is the principal factor in preventing accidents and injuries.

Before starting up the vehicle, carefully read all the instructions in this booklet. Should doubt or uncertainties arise, contact the manufacturing company.

- Before starting the engine, make sure that there are no people near the vehicle, especially children.
- It is strictly forbidden to transport or lift people.
- **Do not** use the vehicle unless you are physically fit.
- **Do not** drink alcoholic beverages while at work.
- This vehicle is not approved for road circulation.
- **Do not** use the vehicle on steep slopes but only on ground with a gradient that is less than the limits indicated further stated in this manual.
- It is strictly forbidden to abandon the vehicle while the engine is running or with the ignition key inserted. The engine must always be stopped.
- It is strictly forbidden for minors to use the vehicle.
- **Do not** use the vehicle in closed or poorly ventilated areas: exhaust fumes are toxic and could be seriously harmful to the body and may even be fatal.

The vehicle must be refuelled with the engine switched off. **Always** keep away from flames and **do not** smoke.

- **Do not** spill hydraulic or lubricating oil or any other liquid on the ground during maintenance; pick it up and dispose of it at authorized companies.
- Unauthorized personnel must be prohibited from operating the vehicle by removing the ignition key. The person it is handed over to is responsible for any harm and damage caused to third parties.
- It is strictly forbidden to remove the safety devices installed.
- Avoid stopping the vehicle in a place where there lies the risk of a landslide, especially when fully loaded.
- Avoid wearing inadequate clothing when operating the vehicle (oil-stained, torn, etc.).
- It is strictly forbidden to stop or park while the engine is running. The engine must always be stopped.

Certain symbols are found in the manual and where necessary on some parts of the vehicle, followed by safety-related messages. For them to be read more easily and carefully, follow the instructions below:



DANGER!

This symbol indicates a high degree of danger and risk for the safety of the operator or other persons, including death. Use all the precautions recommended in this manual.



ATTENTION!

This symbol indicates a potential hazard that can be eliminated by applying and complying with the instructions provided in this manual or by using common sense.

SECTION 1 SAFETY

General Safety (cont'd)

The present manual contains the information required to run the machine. Contact the Manufacturer for any spare parts, accessories or information you might require. The tracked buggy fit with bucket or open dump body serves to carry and dump materials. The materials being handled must comply with the characteristics of the equipment currently being used.

- Avoid abrupt movements. All movements and maneuvers must be performed with utmost care and while running at a slow speed.
- Check that the work area is free and that there are no unauthorized persons around. Also check that no one enters or passes within the machine operating range.
- In case of operating anomalies while moving the various mobile parts of the machine, turn the engine off immediately.
- **Never** perform any checks, controls or maintenance operations with the engine running.
- **Never** transport or lift anyone except the operator.
- When hoisting and transporting the machine, follow the instructions given in this manual.
- Before starting up the machine, make certain that the load has been positioned correctly in the dump body.
- When moving over a slope, whether moving forward or in reverse, always make certain that the weight is evenly balanced. If the unit has a bucket, set it in a position that improves stability.
- **Never** move over terrain that has both a lateral and longitudinal slope. The terrain must be solid and compact.
- Before tipping the hopper or loading bucket, check that the loaded material can slide freely. If the hopper or loading bucket are lifted with the material blocked inside stability may be lost, therefore this operation is prohibited. This situation is riskier if lifting and unloading is carried out laterally.
- The machine can be used for unloading on ground with a gradient lower than 25% (both lateral or longitudinal). It is prohibited to unload where there is a longitudinal and lateral slope present at the same time.
- Lifting of the loading bucket for unloading, must be carried out very slowly to prevent swinging, which could cause the machine to tip over.
- Before lifting the load, check that the material contained in the loading bucket has been positioned in a way to prevent its accidental escape during movement.

- If the loading bucket is also equipped with a shovel, it must be positioned as high as possible, to prevent it from interfering with the remaining structure when tipping over.
- If a transporter equipped with AV or AVP systems is used (high unloading system, variable, with or without loading shovel) the following additional recommendations must be respected:
 - The machine can be used for unloading on land with a gradient lower than 25% (longitudinal) and 18% (lateral). It is prohibited to unload where there is a longitudinal and lateral slope present at the same time.
 - Move the loading system upwards only when the machine is at a standstill (it is not traversing).
 - It is prohibited to traverse with the system lifted, even if only by a few centimetres with respect to the chassis.
 - Before lifting the loading bucket and tipping it, it is necessary to check that this will not interfere with other objects, in particular with electric cables etc.
 - Only use the high tipping system with friable material. On tipping the loading bucket it is necessary to check that the material really does slide downwards.
 - Take great care during the unloading phase. If in doubt lower the loading bucket again and check that the material moves freely. If the material is blocked, try to unblock it with the loading bucket in a low position, otherwise the machine may tip over, crushing the operator and causing damage.

UPHILL OR DOWNHILL - LOADED

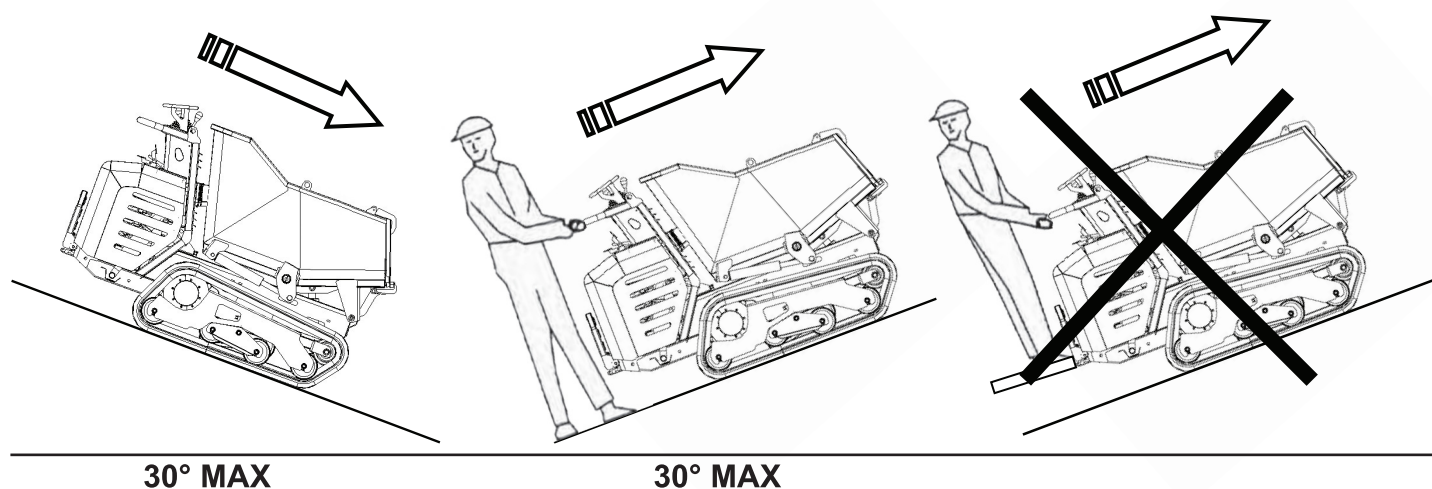

SECTION 1 SAFETY

General Safety (cont'd)

UPHILL OR DOWNHILL - EMPTY

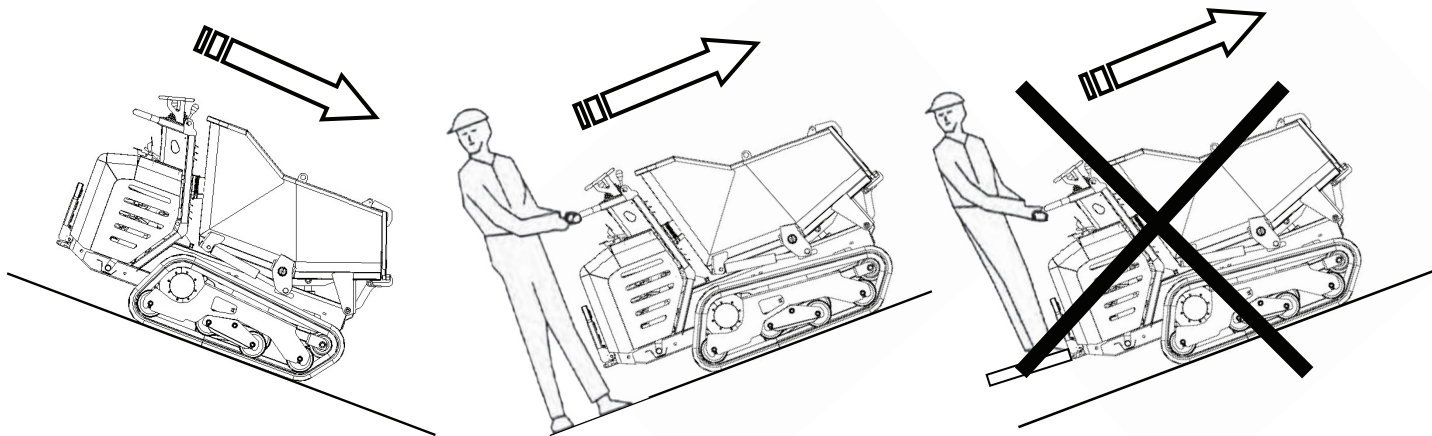

30° MAX

25° MAX

FLAT GROUND - EMPTY

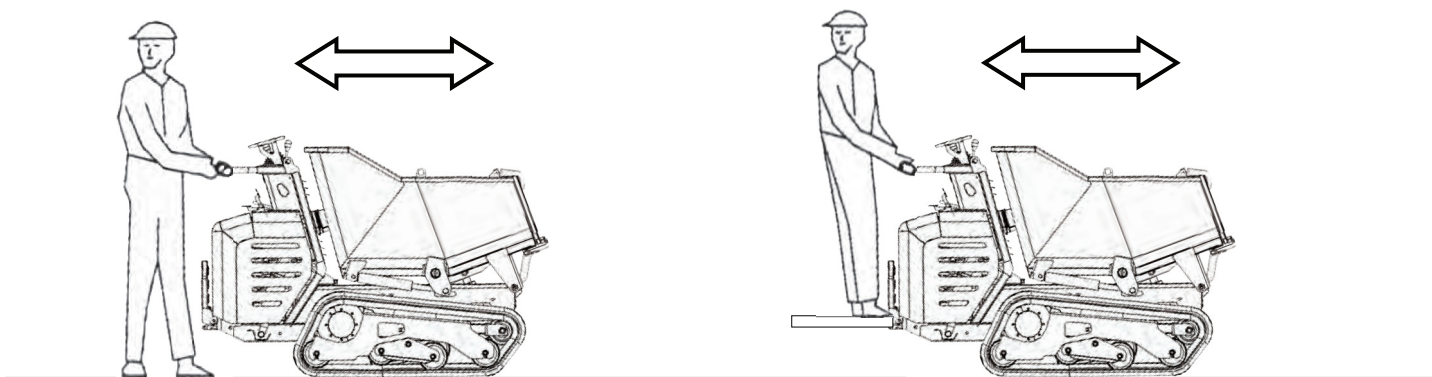

UPHILL OR DOWNHILL, EMPTY AND LOADED

MAX 22 %

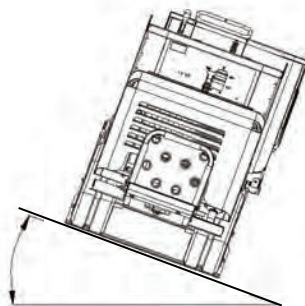

USING THE OPERATOR PLATFORM:

- The PLATFORM must be LIFTED (max. height) with the OPERATOR on the GROUND.
- The PLATFORM must be LOWERED with the OPERATOR ON IT.
- Under no circumstances is the operator to drive while the platform is lowered.



SECTION 1 SAFETY

Lifting and Transportation Safety



The vehicle must only be lifted when empty and it is of utmost importance to strictly comply with the following:

- Lower the load bucket slightly to release the two hooks located on the sides of the dump body: the other two are positioned on the sides of the driving position (see figure).
- Close off the lifting area and prohibit unauthorised people from entering. Do not direct the load over people or things and make sure that the area where the un/loading operations are performed is clear from any obstruction (power cables, telephone line, etc.).
- It is strictly forbidden for people to pass or stand under the suspended load.

- Use cables or chains rated for the weight to be lifted: when empty and fit with bucket, the machine weights approximately 630 Kg. The machine fitted with high tip skip weights approximately 770 Kg.
- Hook the vehicle from the 4 points provided and proceed with the lifting operations; avoid sudden movements and use very low lifting speeds.
- Lift the vehicle and place it on the transport vehicle, then anchor it properly by inserting and blocking wedges at the ends of the tracks on the flatbed.
- If necessary, secure the vehicle to the flatbed with steel cables of adequate capacity.
- Unload the vehicle by following the steps in inverse order and adopting all the necessary safety precautions to safeguard the personnel involved and the vehicle itself.

ATTENTION!!!

It is recommended to close the fuel valve every time the vehicle is transported or handled in order to prevent causing harm or damage.

DANGER ZONES!

Given its functional characteristics, the machine has some pinch points (descent of the body onto the frame, shovel, track) and some shearing points (raising and lowering the shovel arms, dump body hatch). For this reason, particular care must be taken during these movements. Never insert arms or body parts inside these areas.

In case of maintenance, the raised body must be blocked with a special safety item supplied with the machine, that must be inserted on the lifting cylinder ram moving it from position A to position B, as shown in the picture.

Always block with pivot and safety pin. If a shovel is mounted on the machine, it must be secured to the body with cords, etc. To prevent the danger of pinching or shearing, before turning off the engine to park the machine, set the shovel on the ground and return the body to the frame. This precaution is necessary for the safety of the operator or the technician who makes the maintenance

SECTION 1 SAFETY

Safety Retainer Positioning

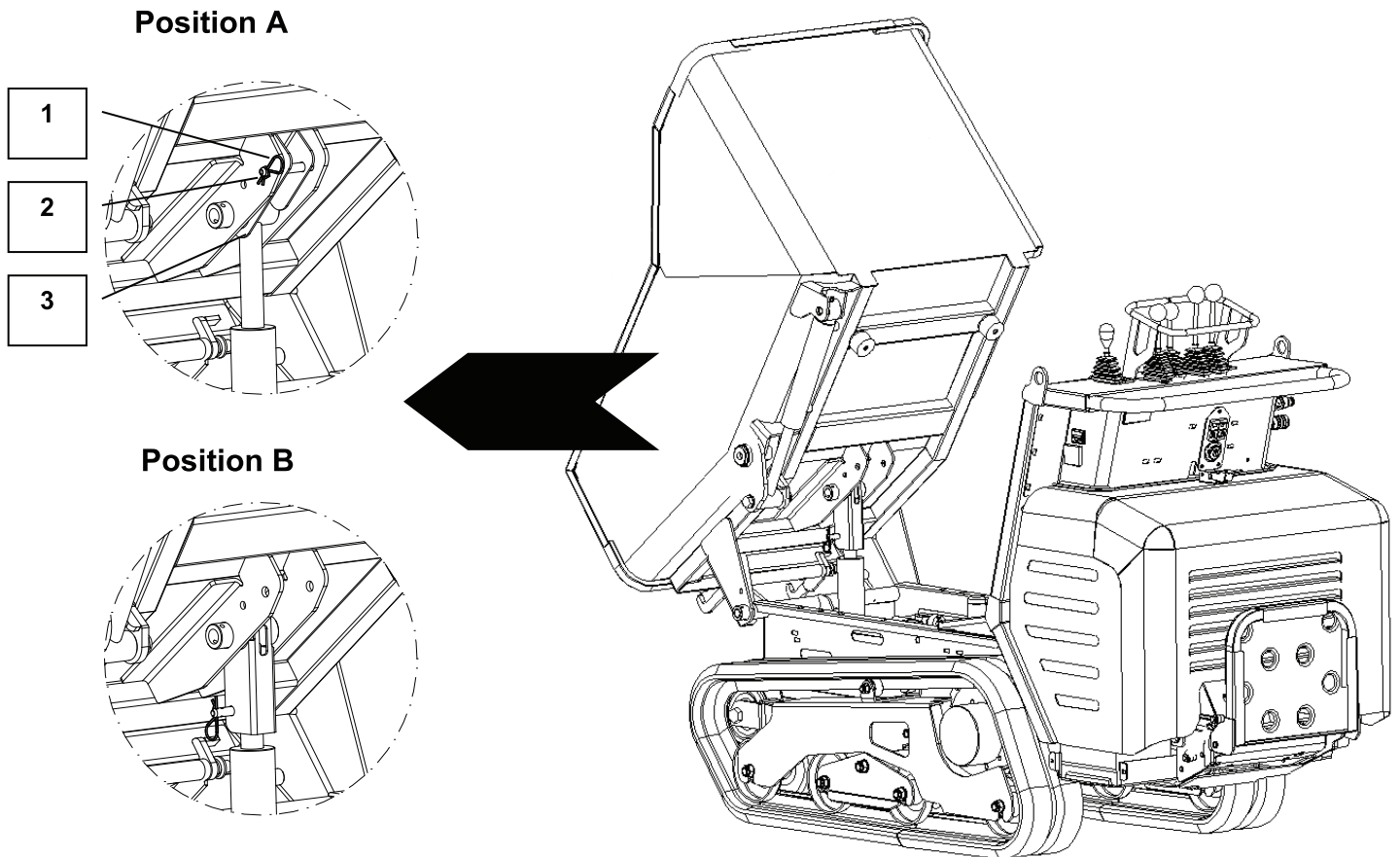

To insert the safety lock make the following operations:

- disconnect the split pin "1";
- unthread the pivot "2";
- rotate the safety lock "3" till enveloping the liner of the lifting cylinder of the body (see "Position B");
- in this position reinsert the blocking elements, pivot and split pin, as shown in the picture "Position B".

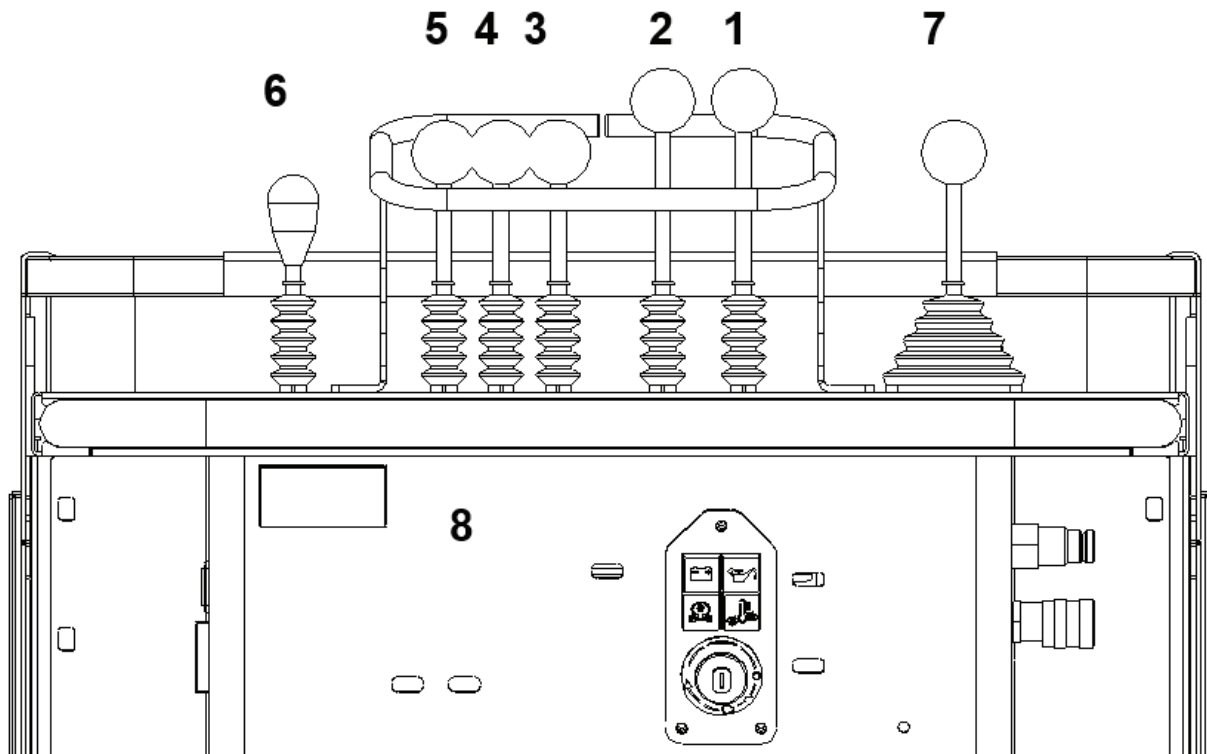

- 1 – RIGHT TRACK DRIVE CONTROL LEVER
- 2 – LEFT TRACK DRIVE CONTROL LEVER
- 3 – LOAD BUCKET UP-DOWN LEVER
- 4 – SELF-LOADING BUCKET LEVER / LOADING BUCKET ROTATION LEVER
- 5 – DRIVING LEVER FOR THE LIFTING OF THE UNLOADING SKIP
- 6 – ACCELERATOR LEVER
- 7 – P.T.O. CONTROL LEVER

SECTION 2 OPERATIONS

General Operating Instructions

The vehicle drive is activated via levers "1" and "2".

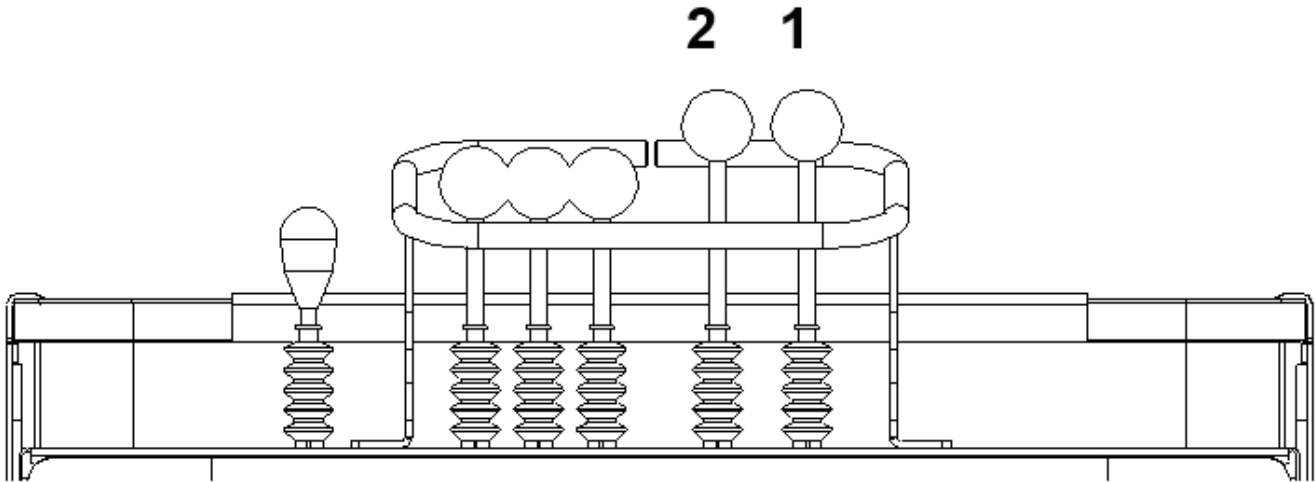

Hereunder are the detailed descriptions of the manoeuvres that are to be performed to drive forward, backward and to steer.

FORWARD GEAR: bring levers "1" and "2" simultaneously forward.

REVERSE GEAR: bring levers "1" and "2" simultaneously backwards.

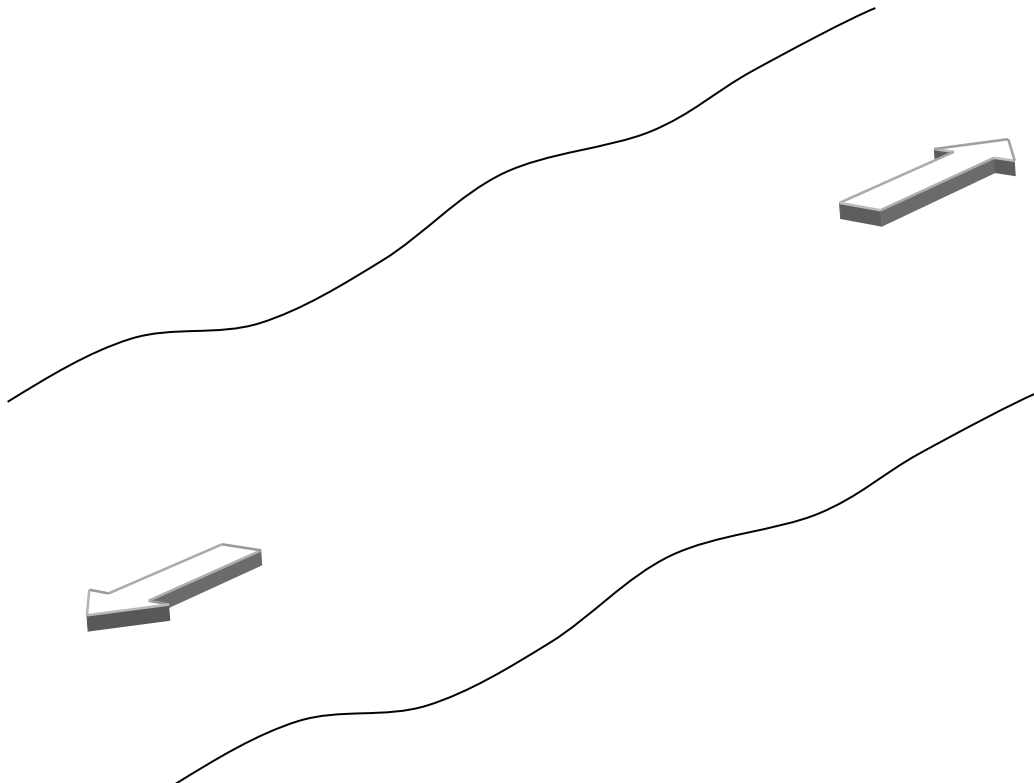

STEERING FORWARD TO THE RIGHT:

WITH THE VEHICLE STOPPED: bring lever "2" forward with respect to lever "1"

WHILE THE VEHICLE IS MOVING: reverse lever "1" with respect to lever "2"

STEERING BACKWARDS TO THE RIGHT:

WITH THE VEHICLE STOPPED: bring lever "2" backwards with respect to lever "1"

WHILE THE VEHICLE IS MOVING: bring lever "1" forward with respect to lever "2"

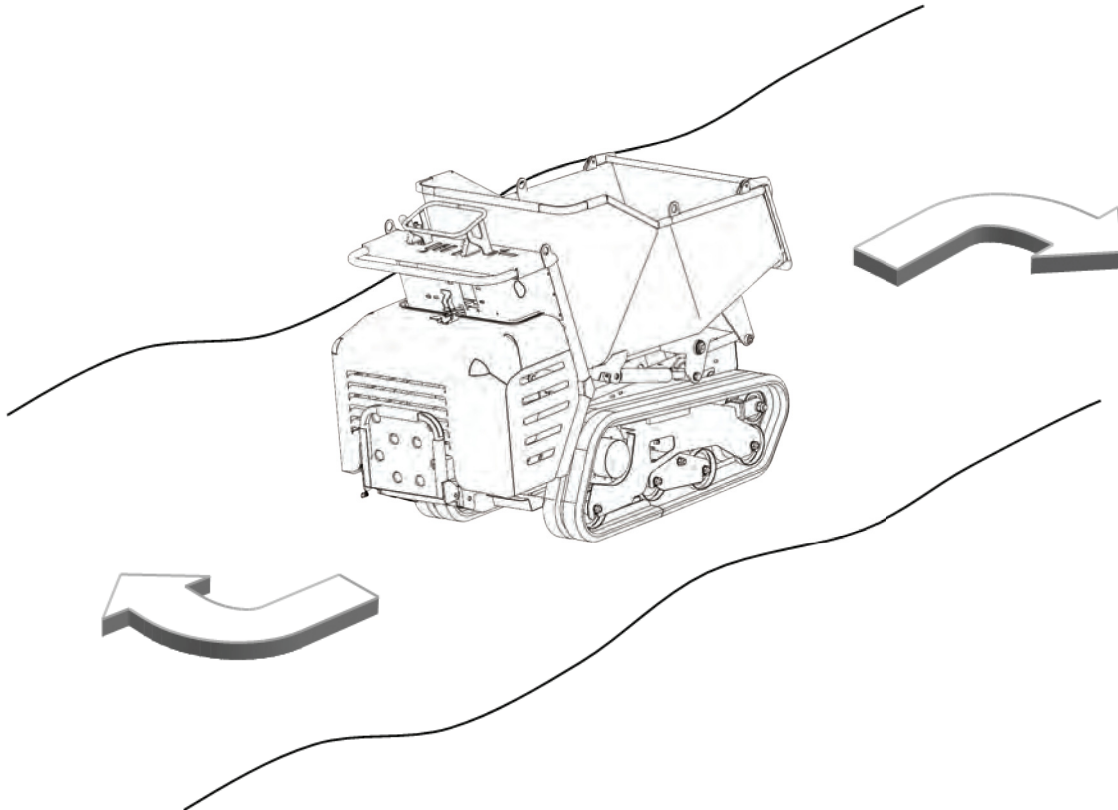

VEHICLE USE

In order to safeguard the integrity and functionality of the track, please follow the recommendations and specifications below:

- Avoid sudden turns and changes in direction while driving on the road, especially on rough and hard ground, bumpy and sharp ground or with high friction. **DO NOT COUNTERSTEER**; turn only one track to go round a bend, both while driving as well as when stationary.
- While driving, prevent the tracks from coming into contact with protrusions and parts with sharp and pointed edges.
- Prevent the tracks from coming in contact with oils, solvents, fuel or other corrosive materials; otherwise, clean and wash immediately.
- Prevent prolonged use of the vehicle in marine areas or in a salty environment, as this enhances the detachment of the metal core from the rubber.

- Due to the basic characteristics of the rubber that the track is made of, it is recommended to use it in temperatures ranging from **-25°C to +55°C**.
- Do not leave the tracks exposed to the elements for prolonged periods; sudden climate changes will enhance premature ageing.
- Any wear on the transmission wheels can cause abrasions or the metal core of the tracks to emerge; these must be promptly replaced.

TROUBLESHOOTING

BROKEN STEEL ROPES OF THE TRACK

- Excessive track tension combined with it being used on stones and loose material that accumulate between the track and the undercarriage.
- The track emerging from the guides on the wheels
- High friction in the case of successive and rapid changes in direction.

WORN OR BROKEN METAL CORES

- Excessive track tension
- Incorrect contact between the sprocket and the track (worn sprocket, debris interposed between the sprocket and the track, etc.)
- Used on sandy ground

DETACHED METAL CORES FROM THE RUBBER

- Excessive abrasion of the inner sides of the track with the guide rollers (excessive and sudden steering and countersteering).
- Worn and entangled sprocket while turning.

ATTENTION!!!

The anomalies listed above require the damaged track to be replaced immediately.

ABRASIONS OR TEARS DUE TO FATIGUE OR EXTERNAL FACTORS

- Generally, these problems are caused by the way the vehicle is used or the environment in which the work is carried out. These changes in the track can be reduced but not eliminated by using the vehicle with care and responsibly, which allow the track to be used without being replaced, even though it is nearing the end of its life cycle and it must be replaced. **It is recommended to replace it even if the tread is reduced to about 2 to 5 mm.**
- Abrasions, tears and cuts on the outer surface of the track (that in contact with the ground) are more often due to contact with sharp stones or cutting material (metal sheets, glass, nails, brick chips, etc.), which cut and partially or completely remove parts of the track. It is clear that from the aspect related to the rubber characteristics, this is inevitable even though it depends on the specific use and service conditions.

NOTE: The integrity of the rubber track and the fact that it wears sooner or later mainly depend on how the vehicle is used.

SECTION 3 SERVICE

General Maintenance

GREASE POINTS

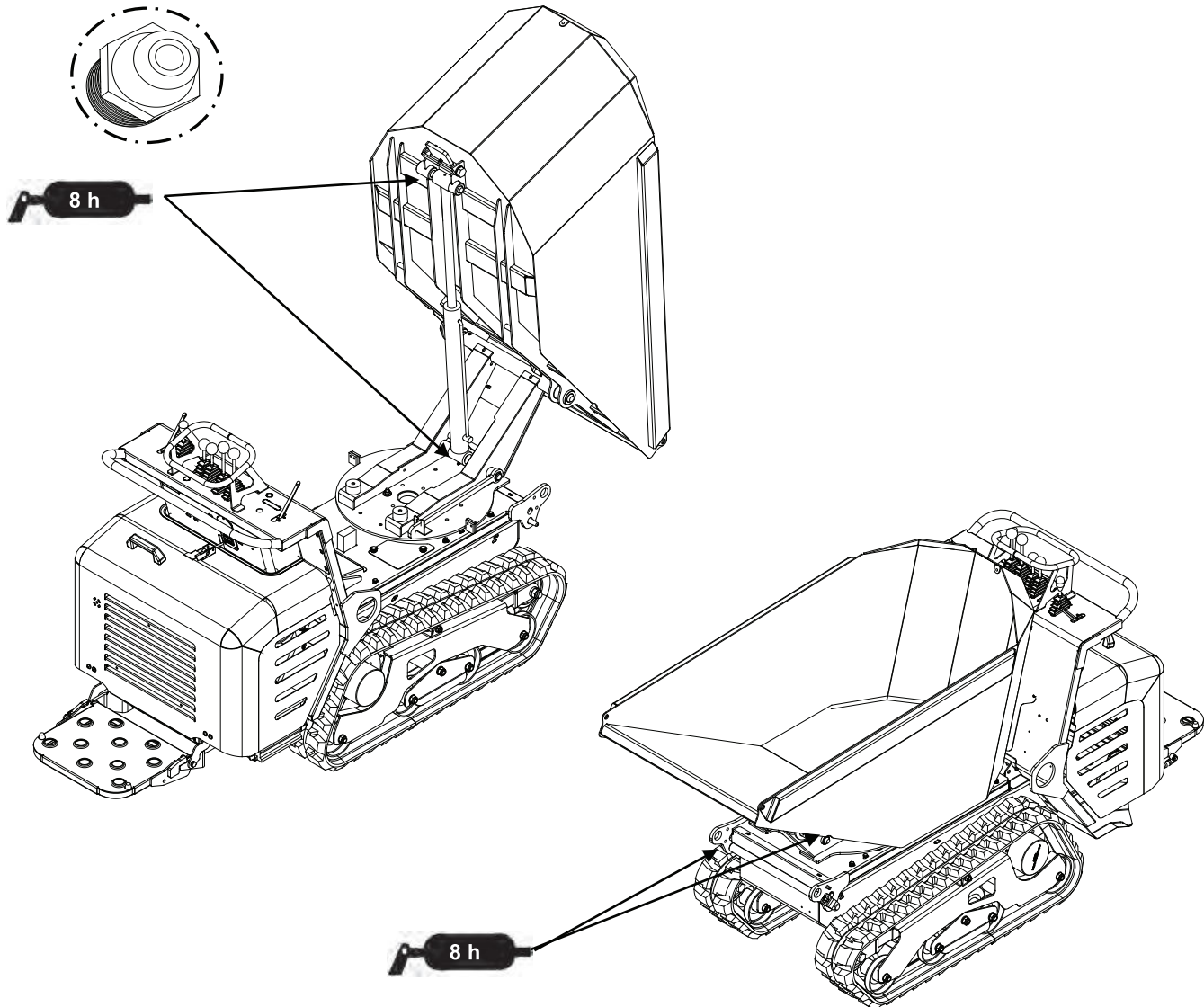

Periodically grease the indicated points. The lubrication intervals and the lubricant that is to be used are indicated in the table of lubricants below.

It is recommended to keep all the grease fittings clean and efficient and replace them if inefficient or damaged.

NOTICE

A thorough inspection and constant greasing allow the vehicle to operate perfectly efficient and safely.

Also grease the parts exposed to the elements as they require adequate protection against oxidation.

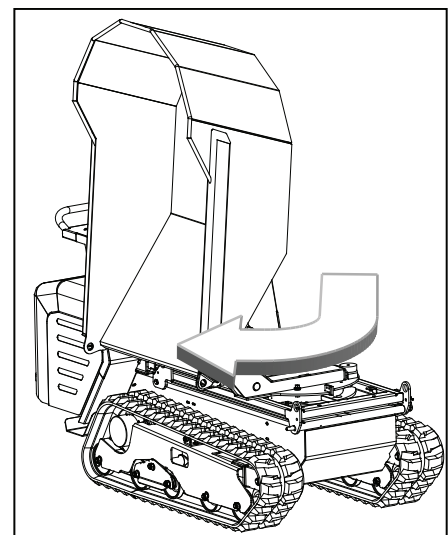
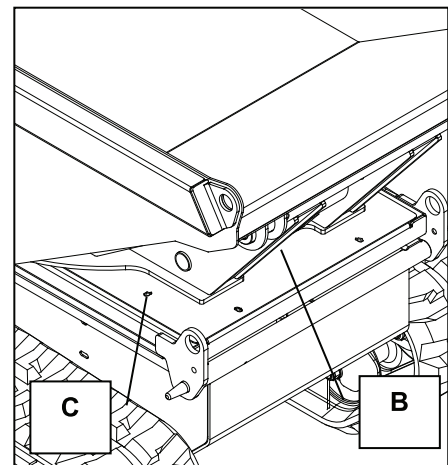
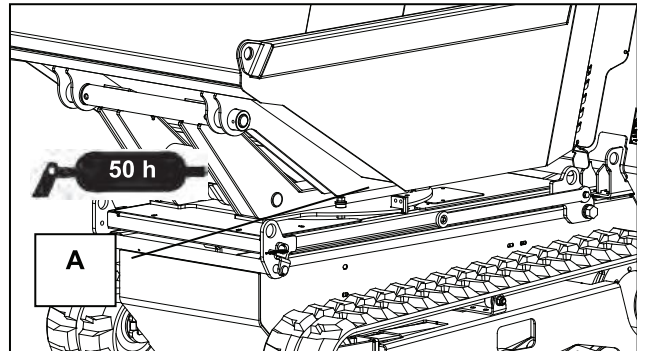

SECTION 3 SERVICE

General Maintenance (cont'd)

Grease the rotation slewing ring through the 2 greasing points "D" and "E", making sure to apply more grease to the front left point "E".

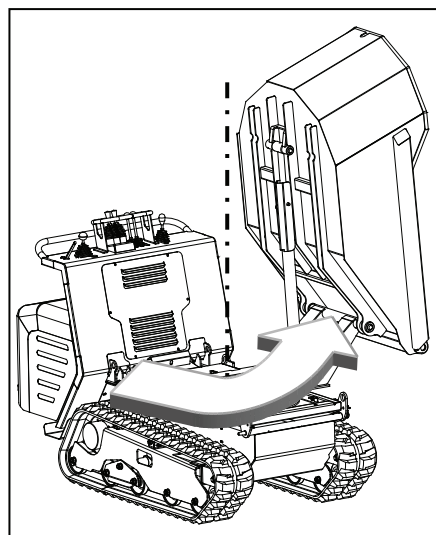
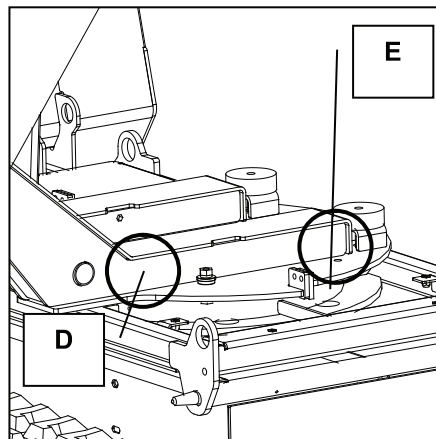

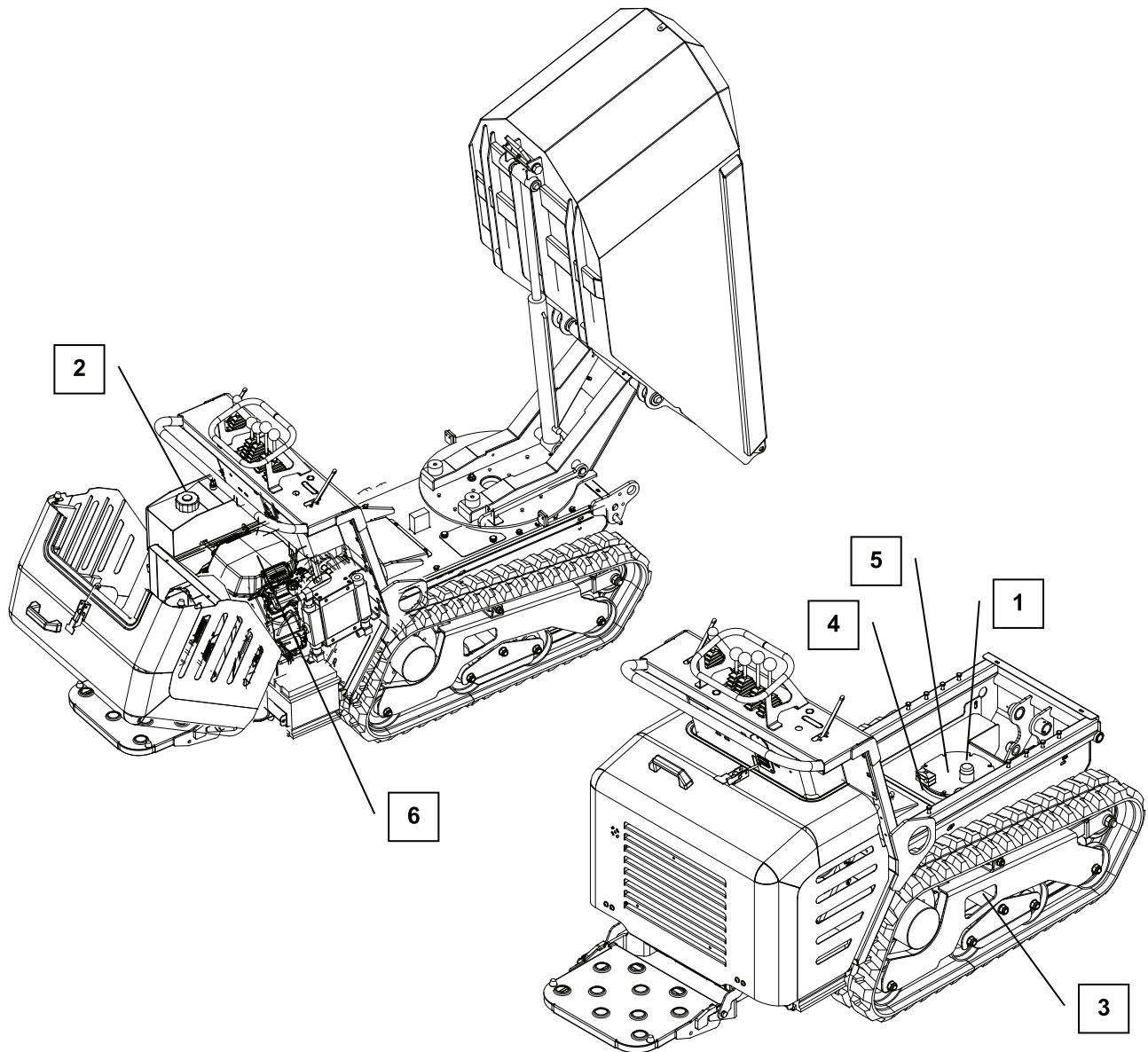

- 1 – HYDRAULIC OIL TANK FILLER CAP
- 2 – FUEL FILLER CAP
- 3 – TRACK TENSIONING DEVICE
- 4 – HYDRAULIC OIL INTAKE FILTER
- 5 – DISCHARGE HYDRAULIC OIL FILTER
- 6 – AIR FILTER

SECTION 3 SERVICE

General Maintenance (cont'd)

1 – HYDRAULIC OIL TANK FILLER CAP

Complete change It. **18.0** Use 46 Weight Hydraulic Oil.

Replace the oil after the first **200 HOURS** of operation and every **1000 HOURS** thereafter or once a year.

To fill or top up, check that the oil is between the min. and max. levels on the dip stick incorporated in the screw down cap. This control must be performed with the bucket raised (cylinder extended) and the machine on a flat surface.

ALWAYS KEEP THE LEVEL BETWEEN MINIMUM AND MAXIMUM

Never overfill because the tank serves as an oil expansion tank during machine operation.

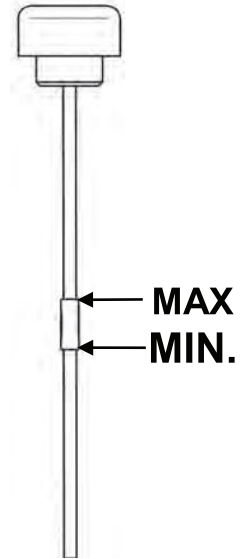

2 – FUEL FILLER CAP

Open the bonnet by acting on the locking device “A” and top-up through cap “B”.

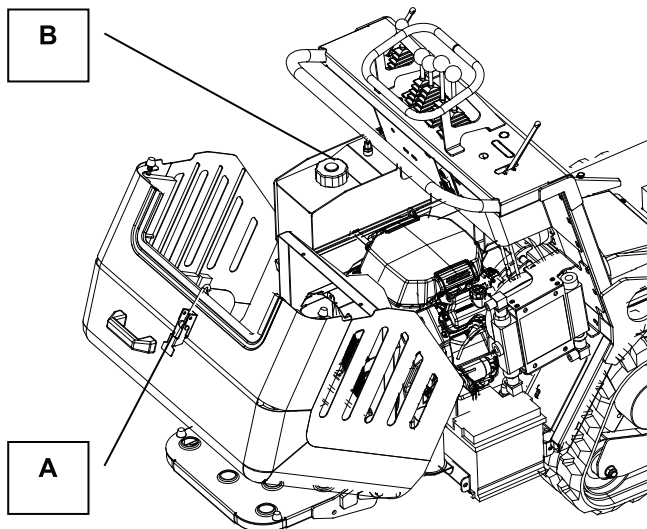

When refuelling, it is recommended to fill the tank up to $\frac{3}{4}$ of the maximum overflow level in order to leave space (about $\frac{1}{4}$) for fuel expansion.

Fuel tank capacity (unleaded fuel): 9.0 lt. / 2.37 gal

3 – TRACK TENSIONING DEVICE

This device is used to restore correct track tightness if they loosen during use.

TIGHTENING THE TRACKS

With use, the tracks tend to loosen.

When operating with loose tracks, they tend to slip over the driving wheel teeth causing it to jump its housing or to work in precarious fashion, damaging and causing wear to the housing.

Never allow this situation to occur. To restore correct track tightness, proceed as follows:

Set the machine on a flat surface with compact ground, better on an asphalt or stone pavement. Lift the machine and set it on blocks or supports rated for the weight of the machine so that the tracks are approximately **100 mm (3.93")** off the ground.

Measure the track midline vs. the horizontal line; the reading must not be more than **5 mm (.19")**.

If the distance is greater, proceed as follows:

- loosen lock nut “**A**”.
- tighten screw “**B**” until the correct tightness is restored.
- lock screw “**B**” tightening lock-nut “**A**” thoroughly.

At this point, track tightness has been restored to the original tension found with new tracks.

Run the track blank for a few minutes so that it can settle in. With the track not running, check that the track tightness is correct. Then raise the machine and set it on the ground. It is now ready to use.

Once a day, clean all moving parts of the machine.

Regularly verify that the pivots that support the rollers “**P**” are securely blocked by making sure that the lock nuts are perfectly tightened.

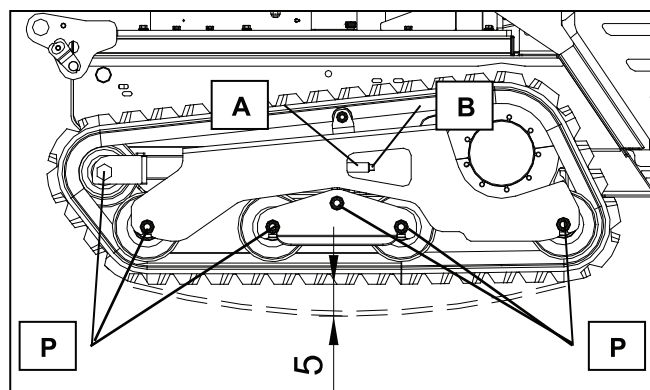

SECTION 3 SERVICE

General Maintenance (cont'd)

REPLACING THE HYDRAULIC OIL INTAKE FILTER

The filter is located inside the hydraulic oil tank (see picture).

Replace the filter after the first **50 HOURS** of operation and every **500 HOURS** thereafter.

Remove the oil tank cover by loosening the screws "A", unscrew the filter "F" and replace it with another having the same characteristics:

Degree of filtration: 30 micron
Nominal flow rate: 25 l/min.

NOTE: each time the filter is replaced, any oil that leaks must not be released in the environment.

IT IS ADVISABLE TO CARRY OUT THIS OPERATION OVER WATERPROOF OR PLASTIC SHEET.

THE OIL MUST ONLY BE DISPOSED OF AT AUTHORIZED COMPANIES.

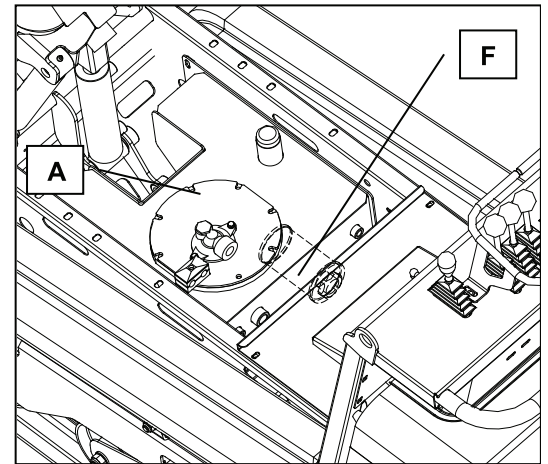

REPLACING THE DISCHARGE HYDRAULIC OIL FILTER

The filter is located inside the hydraulic oil tank (see picture).

Replace the filter after the first **50 HOURS** of operation and every **500 HOURS** thereafter.

Unscrew the filter "F" and replace it with another having the same characteristics:

NOTE: each time the filter is replaced, any oil that leaks must not be released in the environment.

IT IS ADVISABLE TO CARRY OUT THIS OPERATION OVER WATERPROOF OR PLASTIC SHEET.

THE OIL MUST ONLY BE DISPOSED OF AT AUTHORIZED COMPANIES.

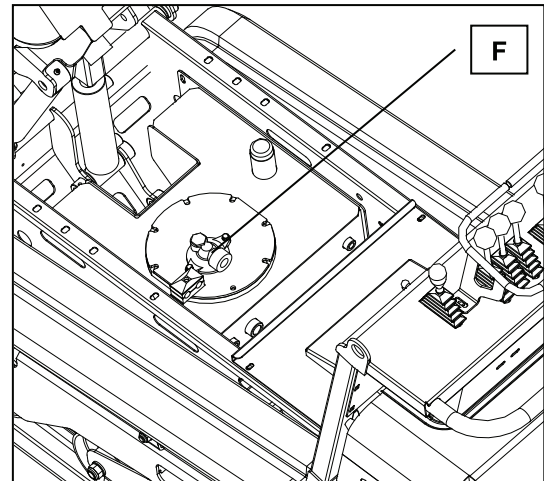

REPLACING THE AIR FILTER

The air filter "F" is located under the engine bonnet.

To clean the cartridge, it is sufficient to remove the top cover, remove the cartridge and clean with compressed air. Do not use solvents, brushes or rags to prevent damage to the cartridge.

The air filter should be replaced with another one having the same characteristics.

The filter should be cleaned every **50 hours** of operation and the replacement must be done every **200 hours**.

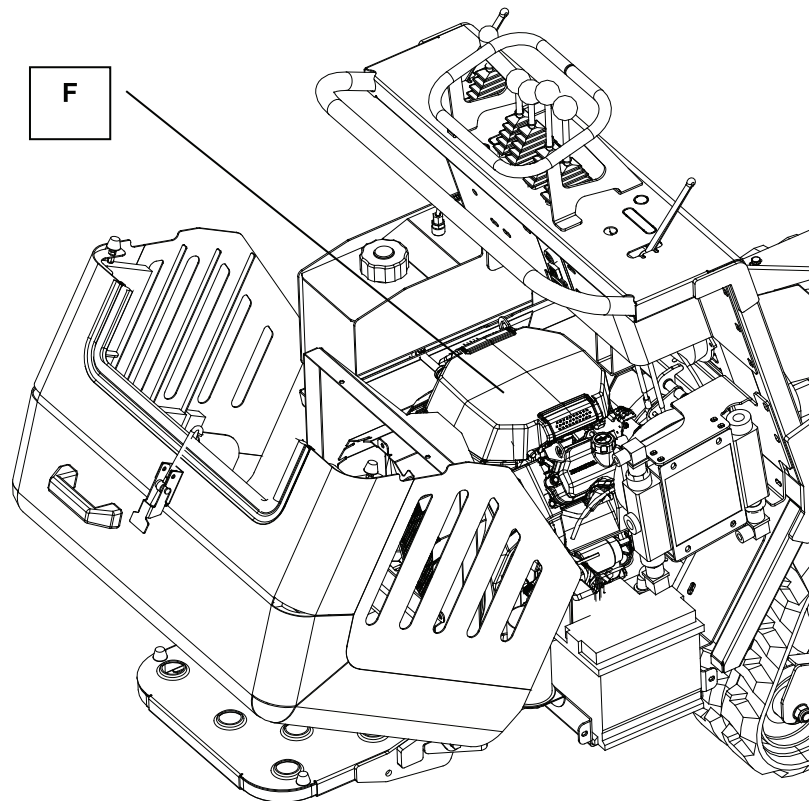

SECTION 3 SERVICE

General Maintenance (cont'd)

WHEEL GEARS

Each track is driven by a reducer, coupled to a hydrostatic motor, fitted with an internal brake with negative-type of multiple discs.

The brake is activated by the hydrostatic system by means of the transmission levers (forward - reverse).

The brake is always engaged (parking) when the engine is off.

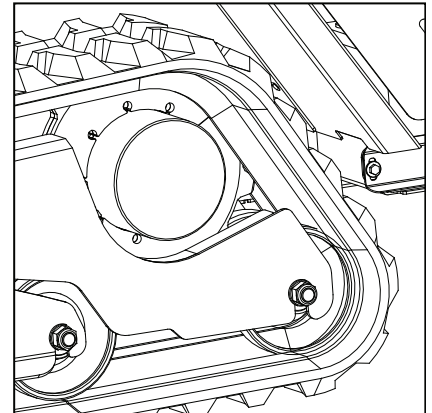

STOPPING THE VEHICLE WITH THE ENGINE OFF IS ALWAYS GUARANTEED WITH THE NEGATIVE BRAKE. WHILE THE ENGINE IS RUNNING, THIS CAN ONLY BE APPLIED BY ACTIVATING THE COMMAND FROM THE DRIVER'S SEAT

MAINTENANCE AND REPAIRS MUST ALWAYS BE PERFORMED BY ADEQUATELY TRAINED PERSONNEL.

INSPECTING, FILLING AND CHANGING THE OIL IN THE WHEEL GEARS

Regularly verify that there are no leaks and that the oil reaches the correct level when the machine is stationary and the reducers are positioned as shown below. If necessary, top-up.

ATTENTION!!! TOPPING UP MORE THAN 10% OF THE TOTAL AMOUNT MAY BE INDICATIVE OF A LEAK IN THE REDUCER.

The oil must be changed after the first 100 hours of operation.

It must then be changed after 2000 hours of operation or once a year.

Capacity of each reducer: 0.5 l

The type is indicated in the relative table of lubricants.

The reducer is emptied immediately after operation, while the oil is still hot, in order to prevent any impurities from depositing.

Be particularly careful when emptying as hot oil may cause severe burns.

Clean the cap with detergent while paying particular attention to cleanliness during the filling phase.

Cleaning is essential for the vehicle and especially the hydrostatic system to operate correctly.

The regular checks on the reducer brake are limited to inspecting the oil level of the reducer itself and verifying there are no external leaks.

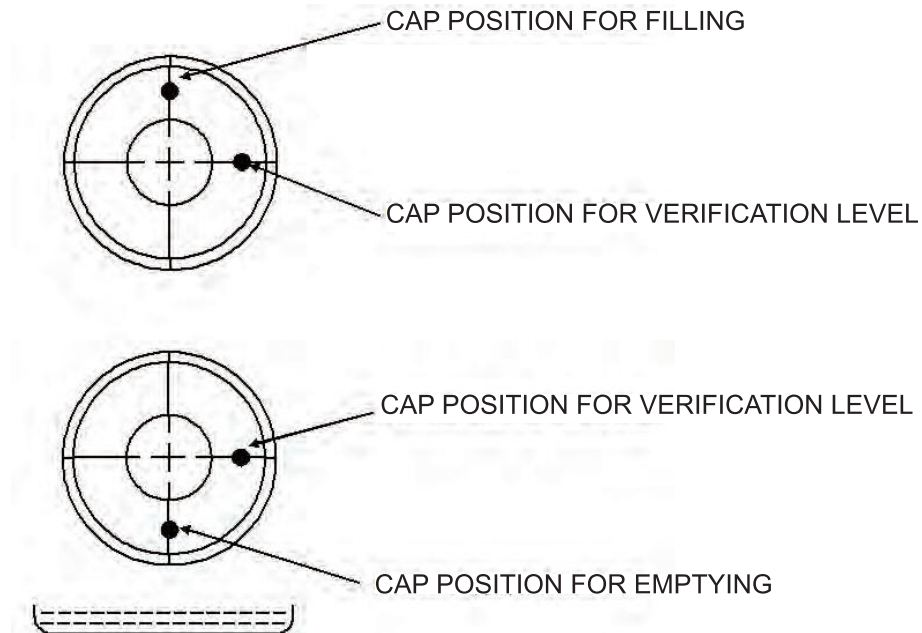

Therefore, this section does not require particular maintenance.

If the oil level in the reducer should decrease or increase when there are no external leaks, the internal seals of the reducer itself must be checked by an authorized service center.

The vehicle must be level and horizontal and the engine OFF when verifying the level, topping up, re-fuelling and emptying.

Insert an adequately sized container under drain plug to collect the oil.

DO NOT DISPOSE OF USED OIL IN THE ENVIRONMENT.

SECTION 3 SERVICE

Maintenance Chart

OPERATION	COMPONENT INVOLVED	HOURS FOR FIRST REPLACEMENT		
		50	100	200
REPLACE	Oil intake filter cartridge	●		
	Discharge oil filter cartridge	●		
	Air filter cartridge			●
	Hydraulic oil			●

OPERATION	COMPONENT INVOLVED	FREQUENCY OF SUBSEQUENT REPLACEMENTS (in hours)					
		8	50	100	200	500	1000
CLEANING	Track	●					
	Loading bucket	●					
	Pump body protection compartment	●					
	Hydraulic oil tank						●
	Air filter cartridge		●				
INSPECTION AND RE-STORE (if necessary)	Track tension		●				
	Hydraulic oil			●			
REPLACE	Oil intake filter cartridge					●	
	Discharge oil filter cartridge					●	
	Air filter cartridge				●		
	Hydraulic oil						●
CLEANING	Grease points	●					

ATTENTION!

Refer to the information provided in the Manufacturer's manual supplied with the vehicle when inspecting the engine.

HYDROSTATIC TRANSMISSION SYSTEM

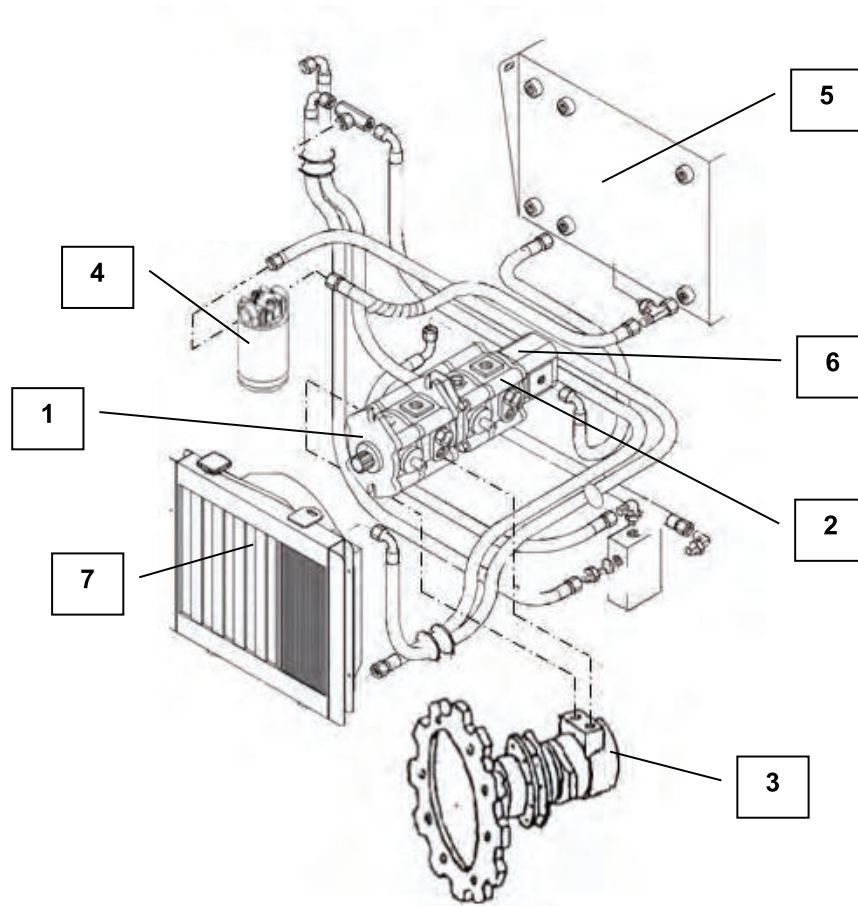

1. RIGHT TRACK HYDRAULIC PUMP
2. LEFT TRACK HYDRAULIC PUMP
3. DRIVE GEARMOTOR
4. DISCHARGE OIL FILTER
5. HYDRAULIC OIL TANK AND OIL INTAKE FILTER
6. SERVICE HYDRAULIC PUMP
7. WATER/OIL COOLER

SECTION 3 SERVICE

General Maintenance (cont'd)

PUMPS MAINTENANCE

In order to service the pump and the hydraulic valve once the body is tipped and safely blocked, loose the screw “U” and “V” and then remove the protection carters

After finished the necessary maintenance, locate again the panels and tie the screws.

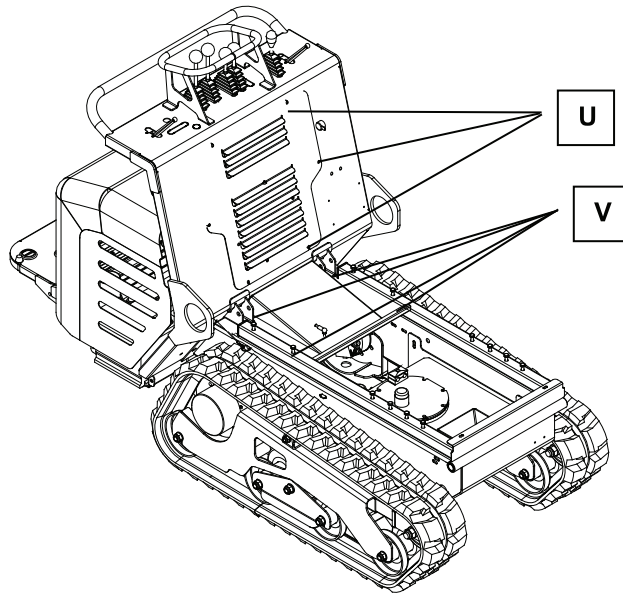

ADJUSTMENT AND ZERO SETTING OF THE HYDRAULIC PUMPS

The track control levers on the control panel automatically return to zero (neutral position), independently of the revolutions of the engine.

If the machine moves slowly forwards or backwards, or rotates slightly, in spite of the fact that the levers are in neutral, it will be necessary to regulate one or both the pumps driving the tracks.

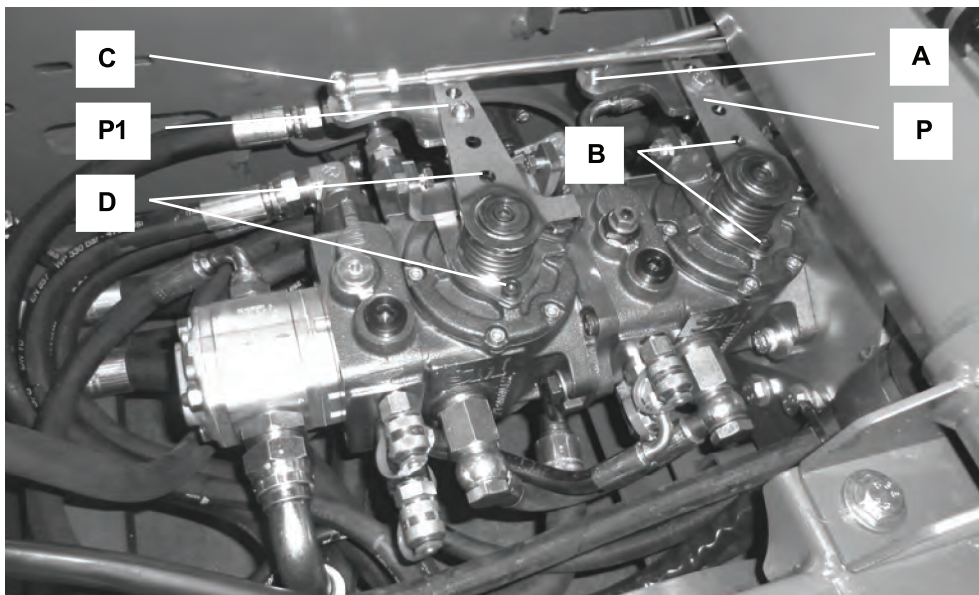

To adjust the pumps and obtain zero setting, proceed in the following order:

- Position the machine on a flat horizontal surface;
- Unscrew the axle bolt on the control cable from the regulating poles “A”, “C” or both;
- Gently loosen screws “B”, “D”, or both of them, using the hexagonal key no.5 to release the break on the adjustment plate “P” or “P1” or both;
- Position the plate “P”, “P1”, or both, in such a way that they lock the tracks and therefore stop the machine;
- Tighten screws “B”, “D” or both, in this position, ensuring the machine is completely immobile;
- Reassemble the axle bolt on the control cable onto the respective parts of the regulating poles “A” and “C”, checking that the speed level of the cable is correct and maintaining the stop position.

ATTENTION!!!

DO NOT INSERT HANDS, PARTS OF THE BODY OR TOOLS IN THE FAN LOCATED ON THE RADIATOR AS IT STARTS AUTOMATICALLY.

IMPORTANT!!!

For proper use of the machine it is recommended to bring the hydraulic oil to work temperature by leaving the engine to idle and slightly accelerated for about 5 – 10 minutes.

NOTE: IN CASE OF ANY DIFFICULTIES OR DOUBTS, IT IS ADVISABLE TO CONTACT AN AUTHORIZED SERVICE CENTER

The track steering control levers on the control panel have an automatic return to zero function (neutral position), regardless of the speed of the endothermic engine.

SECTION 3 SERVICE

General Maintenance (cont'd)

CHECK MAX. PRESSURE OF HYDROSTATIC TRANSMISSION SYSTEM

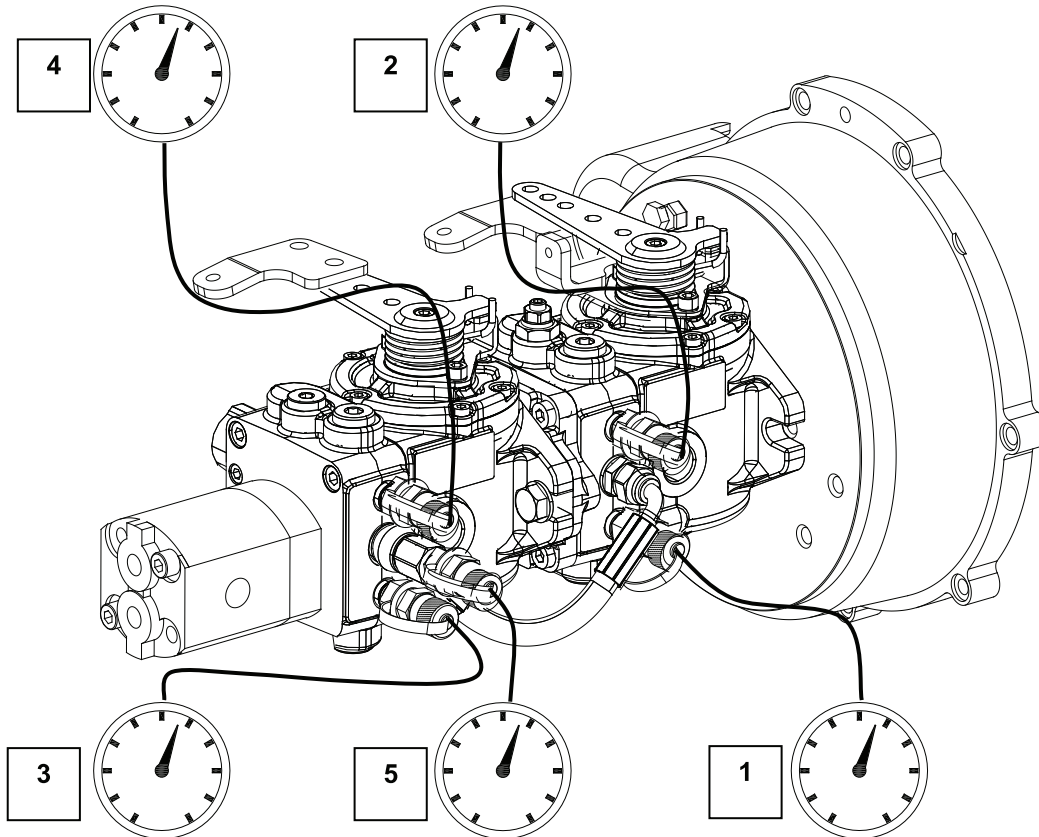

- With the vehicle stationary and the engine off, connect no.4 **400 bar** full scale gauges to points “1”, “2”, “3” and “4”, start the endothermic engine and bring it to the max. power allowed (3200 rpm for the petrol engine and 3600 rpm for the diesel engine).
- Operate the drive lever corresponding to the track to the service of which the gauge has been connected, taking care to block the piloted track and progressively bringing the drive lever completely forwards or backwards.

GAUGE POSITION	CORRESPONDING GEAR	RELATIVE TRACK	PRESS. TO BE READ
1	forward	right	220 ÷ 240 bar
2	reverse	right	
3	reverse	left	
4	forward	left	

- The gauge set at points “1”, “2”, “3” or “4” must indicate a pressure of **250 bar**.

ATTENTION!!!

WHEN TESTING THE 4 SERVICES, THE BOOST PRESSURE READ AT POINT “5” MUST REMAIN UNALTERED, RANGING BETWEEN THE LIMITS INDICATED BELOW (**22 – 24 bar**).

CHECK CHARGE PUMP PRESSURE

- With the machine stopped and engine off, connect up a pressure gauge with bottom scale value **40 bar** to point “5” after which start the engine and run at max.rpm.
- Under these conditions, the shown pressure should be **between 22 and 24 bar**.

GAUGE POSITION	FUNCTION	PRESS. TO BE READ
5	Charge pump	20 ÷ 22 bar

SECTION 3 SERVICE

General Maintenance (cont'd)

CHECK MAX. PRESSURE OF THE HYDRAULIC SYSTEM SERVICE PRESSURES

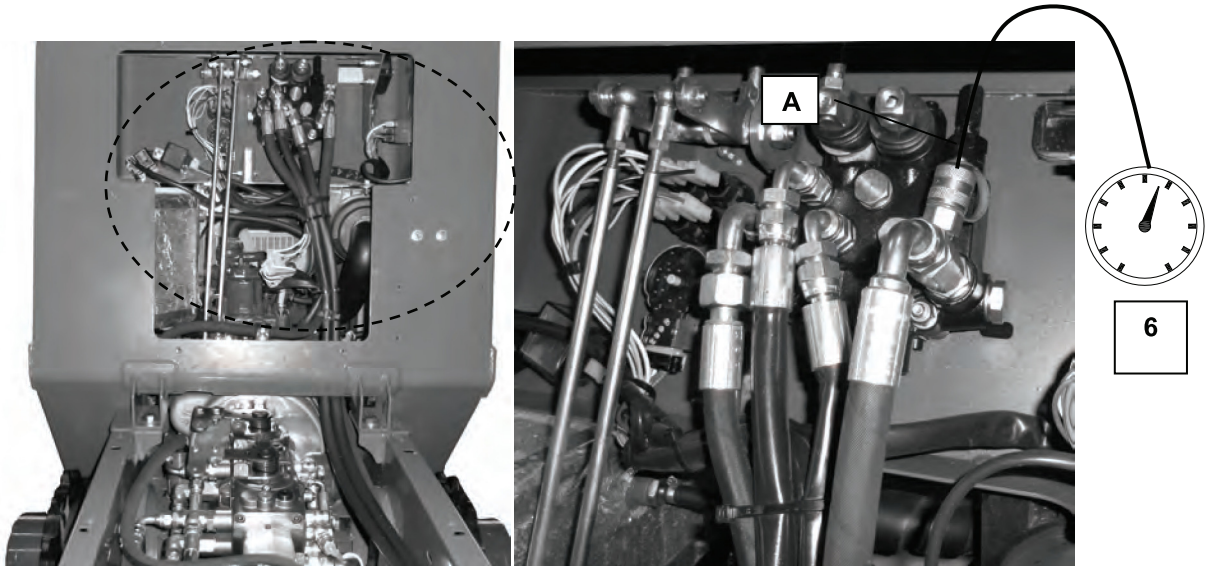

The operation consists of detecting the main valve maximum pressure. Verify by following the instructions below:

- With the vehicle stationary and the engine off, connect a **250 bar** full-scale gauge to position “6”
- Start the engine and bring it to a speed of about 2600 rpm (ACCELERATOR LEVER = $\frac{3}{4}$ OF THE MAX. RANGE) then read the pressure indicated on the gauge
- If the detected pressure differs from the calibration value (**160 bar**) by over 5 bar, restore it by acting on the adjusting screw “A” at the end of the distributor pressure relief valve.

Complete all the verifications and inspections, bring the hydraulic service system and the hydrostatic drive system to the initial operating conditions.

NOTE: for the pressures to be set correctly, it is recommended to take the above mentioned readings with the hydraulic oil at an operating temperature of about 65° C.

It is also advisable to have the above mentioned checks and inspections carried out by an authorized workshop and always in compliance with the instructions provided by the TECHNICAL SUPPORT DEPARTMENT.

GAUGE POSITION	PRESS. TO BE READ	FULL SCALE GAUGE	TYPE	RPM
6	160 ± 5 bar	250 bar	¼" G	2600 rpm

ELECTRICAL SYSTEM

Battery “**B**” is found under the bonnet, on the left side.

BATTERY SPECIFICATIONS:

VOLTAGE: 12 V
CONSUMPTION: 55 Ah
DISCHARGE: 450 A

A - IGNITION KEY

B - BATTERY

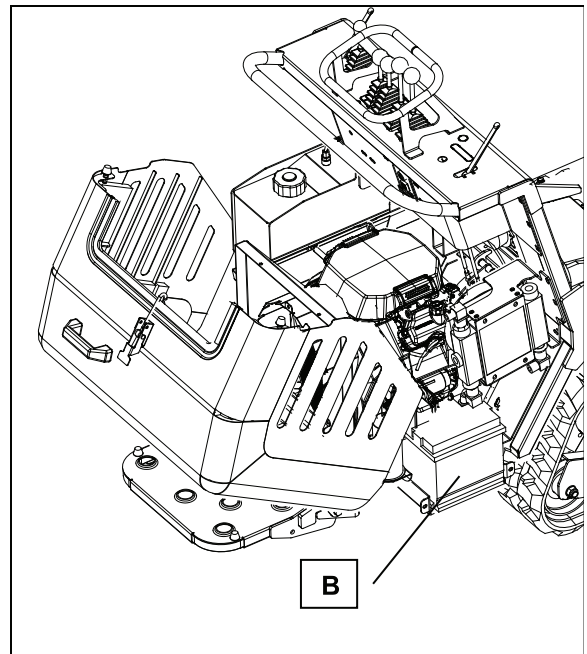

The key in switch “**A**” is only removed when this is disconnected (“OFF” position).

ATTENTION!

Verify the level of the battery liquid every **100 HOURS**.

Follow the instructions found on the casing of the battery itself to check the level.

Only distilled water must be used to top-up - do not use acid. The electrolyte may leak due to it reaching boiling point and cause severe burns.

Always make sure the filler caps are closed perfectly.

Do not drain the battery completely.

If it drains quickly, have the voltage regulator checked. If this is not the cause, recharge the battery or possibly replace it.

The used battery must be disposed of by an authorized Company or personnel.

THE LIQUID INSIDE THE BATTERY IS HIGHLY CORROSIVE. PROTECT YOUR EYES AND HANDS WHEN CHECKING AND RESTORING THE LEVEL.

RISK OF BURNS!
RISK OF SCALDING!!



SECTION 3 SERVICE

General Maintenance (cont'd)

Keep the cable terminals fastened well and protected with grease or even better with pure Vaseline.

When disconnecting the battery, the earth wire (-) must be disconnected first.

When connecting the battery, the positive wire (+) must be connected first.

Keep metal tools and objects away from the battery poles as these may short-circuit the terminals and pose a risk of burns.

Always contact **Authorized Workshops** to charge the battery.

When parking the machine for a long period of time at low temperatures, the battery should be protected or stored in a dry and protected area.

REMOVE THE COVERING BEFORE IGNITION; FIRE HAZARD.

The machine is equipped with a **switch "I"** located on the left side of the machine, it makes it possible to disengage the battery if any **EMERGENCY** required it or if stopping the machine for a long period of time (more than 4 hours). Always contact Authorized Workshops for recharging.

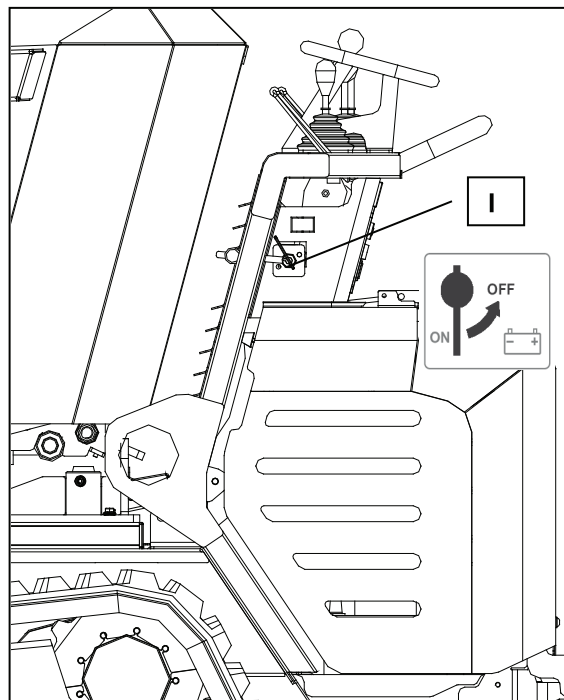

PROBLEM	CAUSE	
The vehicle jerks	No oil in the tank	Check the level and top-up, if necessary
	Air in the hydraulic drive system	Verify the efficiency of the pipes and fittings
	Clogged hydrost. oil filter	Replace the filter cartridge
	Control levers operated too abruptly and quickly	Operate the lever gently
The vehicle does not make use of all its power and does not perform at its maximum performance levels	Use different hydrostatic oil from that indicated	Check and replace it with adequate oil, if necessary
	Clogged hydrostatic oil filter	Replace the filter cartridge
The track tends to come out from its housing	Loosened track due to use	Adjust in accordance with the instructions provided in the paragraph CHECKS AND INSPECTIONS of the GENERAL MAINTENANCE
One of the two tracks is blocked	A foreign body is lodged between the track and the chassis	Remove the foreign body
	Faulty hydrostatic motor	Contact an authorized workshop
	Damaged pump	Contact an authorized workshop
	Broken hydraulic pipes	Check and replace, if necessary
The engine does not start	Burnt spark plugs	Verify the integrity of the spark plugs and the electrical circuit and replace, if necessary
	Flat battery / oxidised terminals	Verify and clean or replace
	Empty fuel tank	Check and top-up, if necessary
	Incorrect fuel	Verify and if necessary, replace after cleaning the tank
	Damaged starter or electromagnet	Contact an authorized workshop
The loading tipper does not rise or tilt	Faulty joint and/or hydraulic pump	Check and replace, if necessary
	Broken hydraulic pipes	Check and replace, if necessary
	Distributor pressure too low	Verify and restore, if necessary
The vehicle does not move in either direction even though the levers are operated Problems in the drive system (the vehicle does not move or steer)	Damaged cylinder or sealings	Verify and replace, if necessary
	Broken hydraulic pipes between the hydrostatic motor and the pump	Verify and replace, if necessary
	Damaged hydrostatic motor and/or pump	Contact an authorized workshop
	Overheated hydraulic oil	Wait for the hydraulic oil to cool down sufficiently and try again
Despite the lever is operated, the corresponding track does not move	Faulty hydraulic pump	Contact an authorized workshop
	Broken hydraulic pipes	Check and replace, if necessary
Excessively overheated hydraulic oil	Low hydraulic oil level	Verify and restore, if necessary

SECTION 4 PARTS

Frame Assembly Illustration

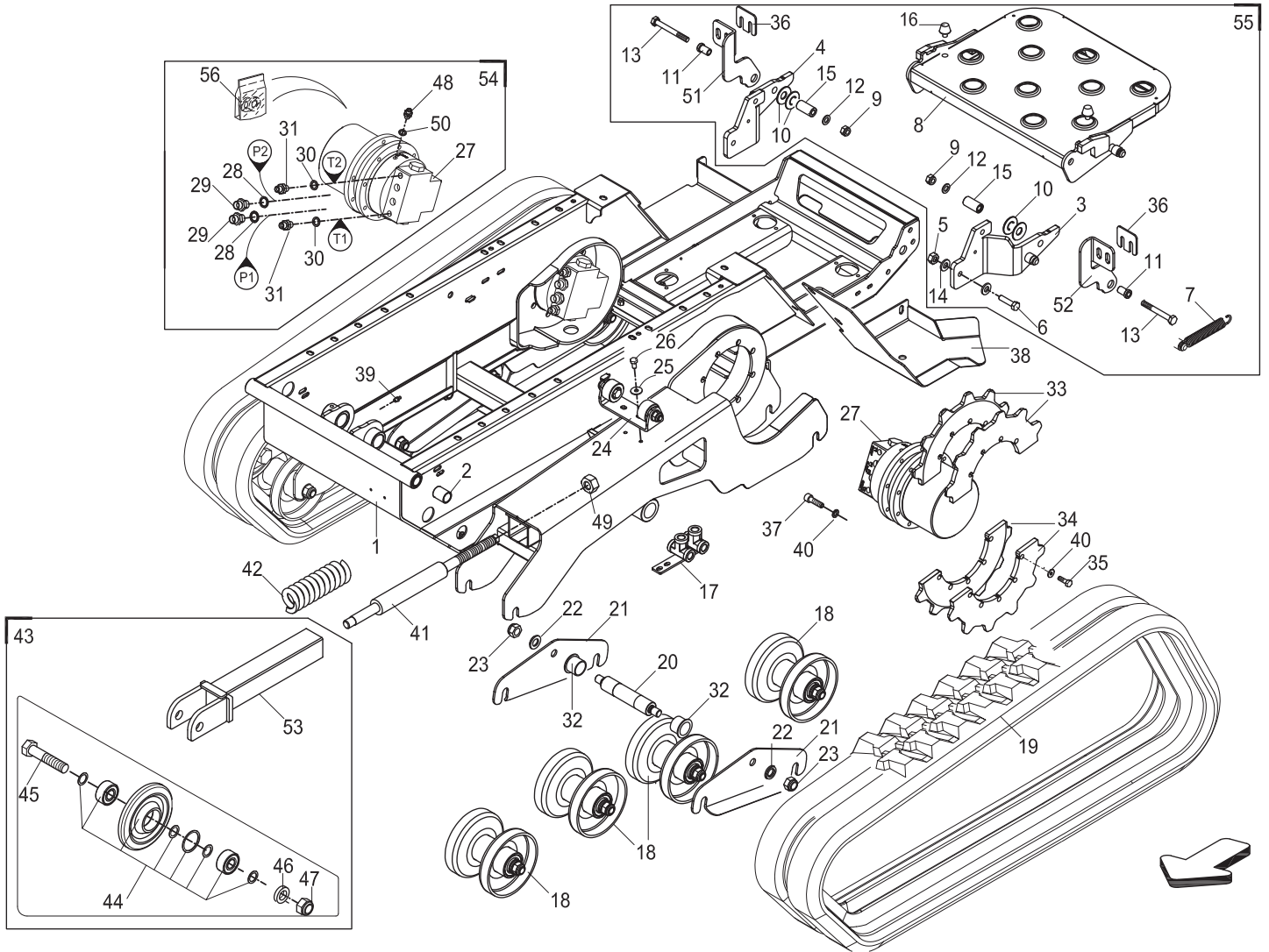

Frame Assembly Parts List

SECTION 4 PARTS

Item	Part #	Description	Qty
1	55141569	FRAME	1
2	33591805	BUSHING	2
3	30060578	PLATE	1
4	30060575	RIGHT MOUNTING	1
5	03366300	NUT	4
6	03240701	FSTN, SCREW M10X40 8.8	4
7	03730003	SPRING	1
8	30060568	OPERATOR'S FOOTBOARD	1
9	03366300	NUT, M10	2
10	03731430	SPRING	4
11	45020435	SPACER	2
12	03386201	FSTN, WASHER 10,5x21x2	2
13	03241600	FSTN, SCREW M10x90 8.8	2
14	03383201	FSTN, WASHER 10,5x21x2	8
15	45020437	SPACER	2
16	03529600	VIBRATION-DAMPING	2
17	25200637	CONNECTOR	1
18	065250	COMPLETE ROLL	8
19	065251	TRACK	2
20	45070954	PIN, 180x72x37	2
21	55140802	SUPPORT	4
22	03389300	FSTN, WASHER 17x30x4	4
23	03389300	FSTN, WASHER 17x30x4	4
24	065257	COMPLETE ROLL	2
25	03385050	WASHER	4
26	03230701	FSTN, SCREW M8x30 8.8	4
27	065252	TRANSLATION GEAR MOTOR	2
28	03160902	WASHER	4
29	13152800	JUNCTION	4
30	03160901	WASHER	4
31	13152700	JUNCTION	4
32	33593670	BUSHING, 30x34x26 IGUS	4
33	065253	GEAR	4
34	065254	GEAR	4
35	03245010	FSTN, SCREW M10x35 12.9	18
36	30014755	SPACER	2
37	03244810	FSTN, SCREW M10x25 12.9	16
38	30014939	CRANKCASE	1
39	03510400	LUBRICATOR	1
40	03386000	WASHER 10,2x17,2x2,2	32
41	45070957	PIN	2
42	03730930	SPRING	2
43	45040156	TRACK STRETCHER	2
44	065256	GEAR	2
45	45071343	PIN, 20x97-M20x1,5	2
46	03390710	WASHER, 21x37x4	2
47	03371110	FSTN, NUT M20x1,5	2
48	13150402	CONNECTOR	2
49	03371120	FSTN, NUT M20	2
50	03160900	WASHER	2
51	30014897	CLAMP	1
52	30014898	CLAMP	1
53	45153316	SUPPORT	2
54	98080002	KIT GEAR MOTOR	2
55	98080001	KIT OPERATOR'S FOOTBOARD	1
56	065255	KIT SEALS	1

SECTION 4 PARTS

Hydraulic Tank Assembly Illustration

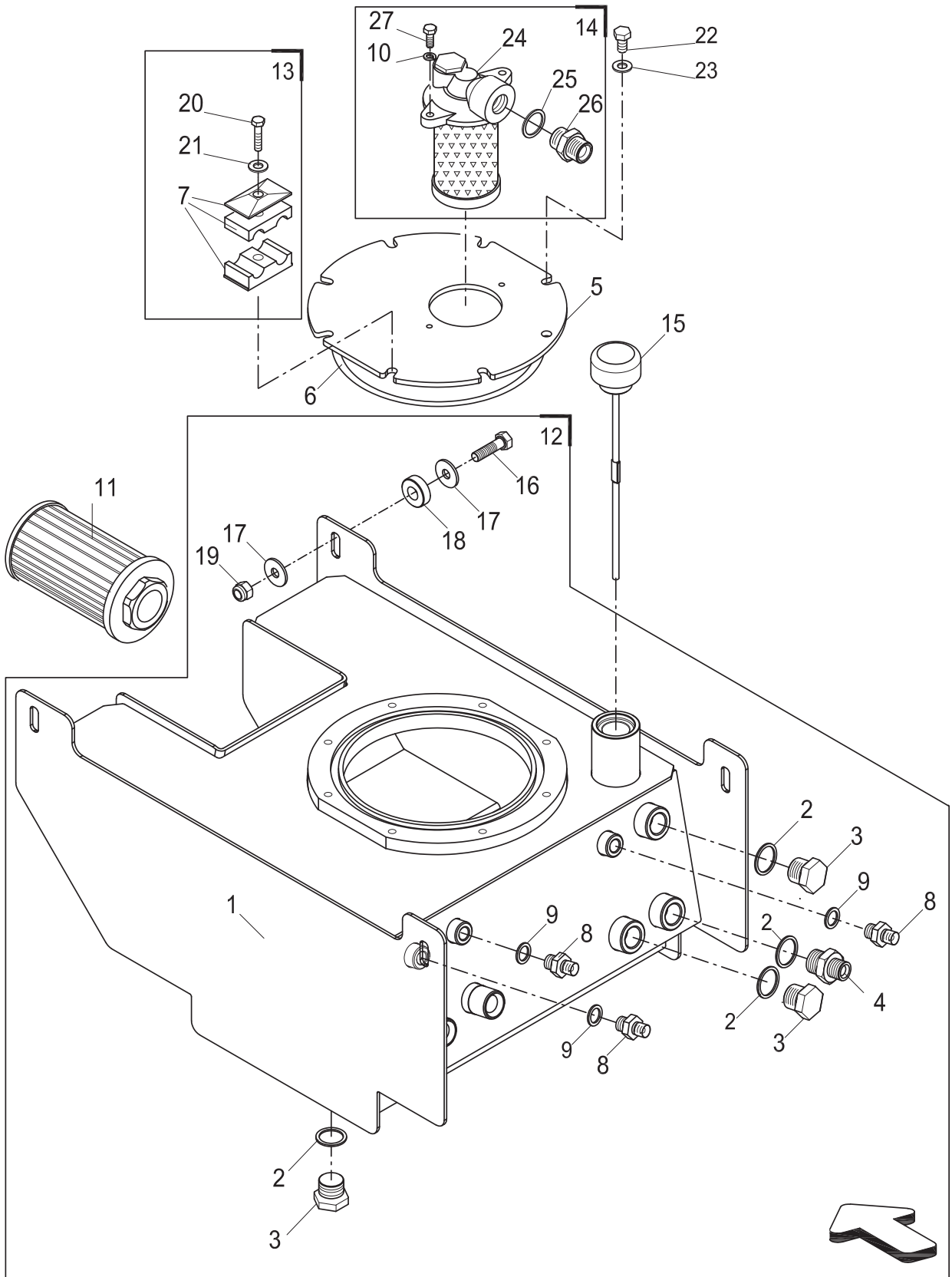

Hydraulic Tank Assembly Parts List

SECTION 4 PARTS

Item	Part #	Description	Qty.
1	15101373	OIL TANK	1
2	03160006	WASHER	4
3	13166000	PLUG	3
4	13153900	JUNCTION	1
5	15101265	COVERING	1
6	03491002	O.R. RING	1
7	13572402	COLLAR	2
8	13150036	REDUCTION	3
9	03160901	WASHER	3
10	03383000	WASHER	2
11	065259	FILTER	1
12	98080003	OIL TANK KIT	1
13	98080004	KIT COLLAR	1
14	98080005	FILTER KIT	1
15	25110025	LEVEL-LOADING PLUG	1
16	03230701	FSTN, SCREW M8x30 8.8	2
17	03385401	WASHER	4
18	45070727	SPACER	2
19	03365100	FSTN, NUT M8	2
20	03231050	FSTN, SCREW M8x45 8.8	2
21	03385600	WASHER	2
22	03220401	FSTN, SCREW M6x16 8.8	6
23	03385600	WASHER	8
24	065258	FILTER	1
25	03160006	WASHER	1
26	13152900	JUNCTION	1
27	03220601	FSTN, SCREW M6x20 8.8	2

SECTION 4 PARTS

Engine Assembly Illustration

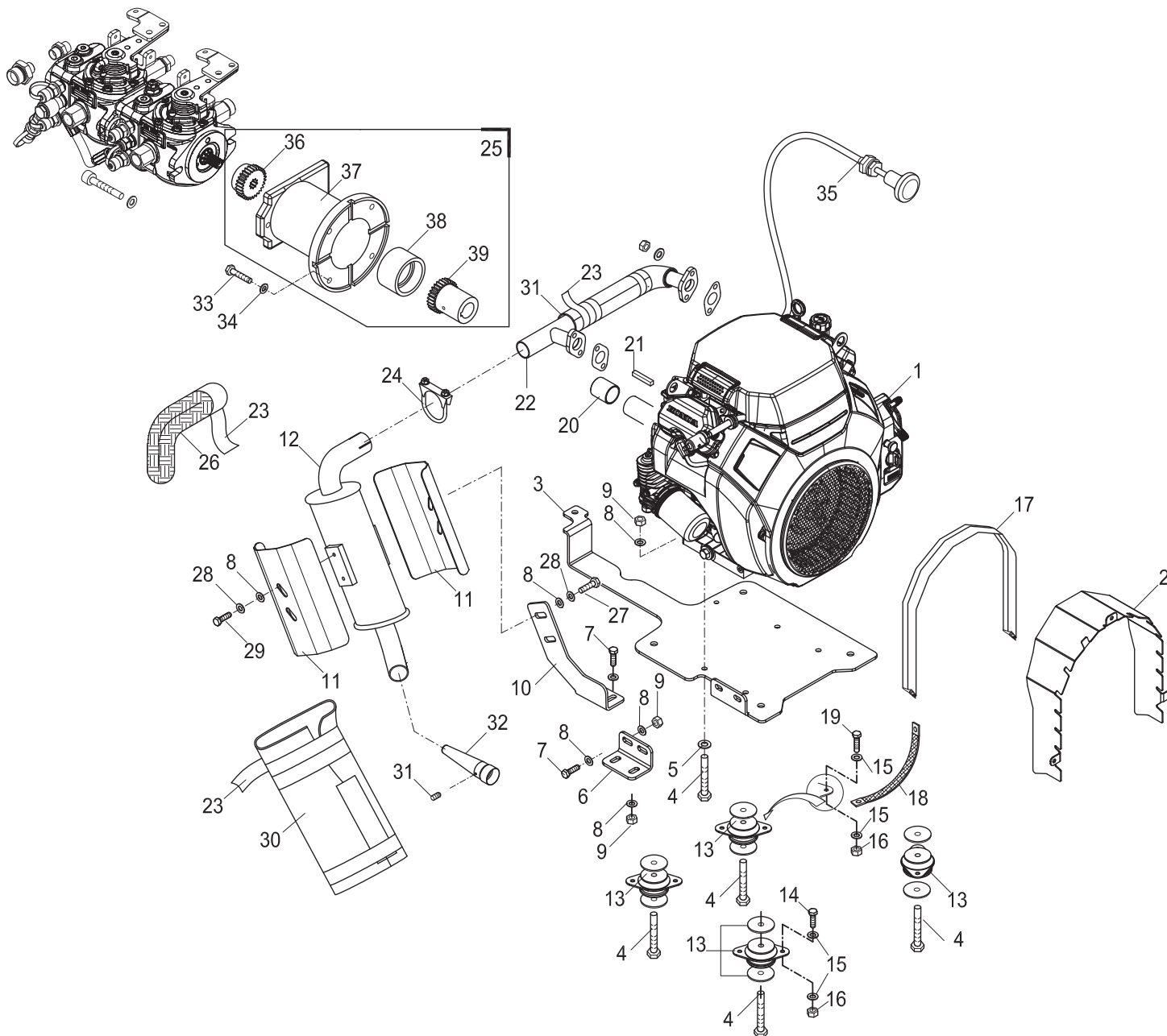

Engine Assembly Parts List

SECTION 4 PARTS

<i>Item</i>	<i>Part #</i>	<i>Description</i>	<i>Qty.</i>
1	13001022	ENGINE	1
2	30014951	CONVEYOR	1
3	20051926	MOTOR BASE	1
4	03231111	FSTN, SCREW M8x50 8.8	8
5	03385201	WASHER	4
6	20051903	CLAMP	1
7	03230601	CLAMP	4
8	03385401	WASHER	16
9	03365101	FSTN, NUT M8	8
10	20051904	CLAMP	1
11	20051905	CLAMP	2
12	03009696	MUFFLER	1
13	03520001	VIBRATION-DAMPING	4
14	03220601	FSTN, SCREW M6x20 8.8	7
15	03383201	WASHER	16
16	03364004	FSTN, NUT M6	8
17	30320363	GASKET	1
18	13467900	EARTHING CABLE	1
19	03220701	FSTN, SCREW M6x25 8.8	1
20	45020371	SPACER	1
21	03415001	KEY	1
22	20051897		1
23	20051354	ADHESIVE TAPE	1
24	13570012	COLLAR	1
25	065260	COUPLEUR	1
26	20051863	PROTECTION	1
27	03230601	FSTN, SCREW M8x25 8.8	2
28	03386050	WASHER	4
29	03230000	FSTN, SCREW M8x10 8.8	2
30	30322200	SCREW	1
31	72207501	DOWEL	1
32	13009604	KIT SPARK ARRESTER	1
33	03237553	FSTN, SCREW 5/16"-24 x 1"1/4	4
34	03385050	WASHER	4
35	03560024	CABLE	1
36	63529618	HUB	1
37	63529617	MOUNTING	1
38	63529620	SLEEVE	1
39	63529619	HUB	1

SECTION 4 PARTS

Hydraulic Pump Assembly Illustration

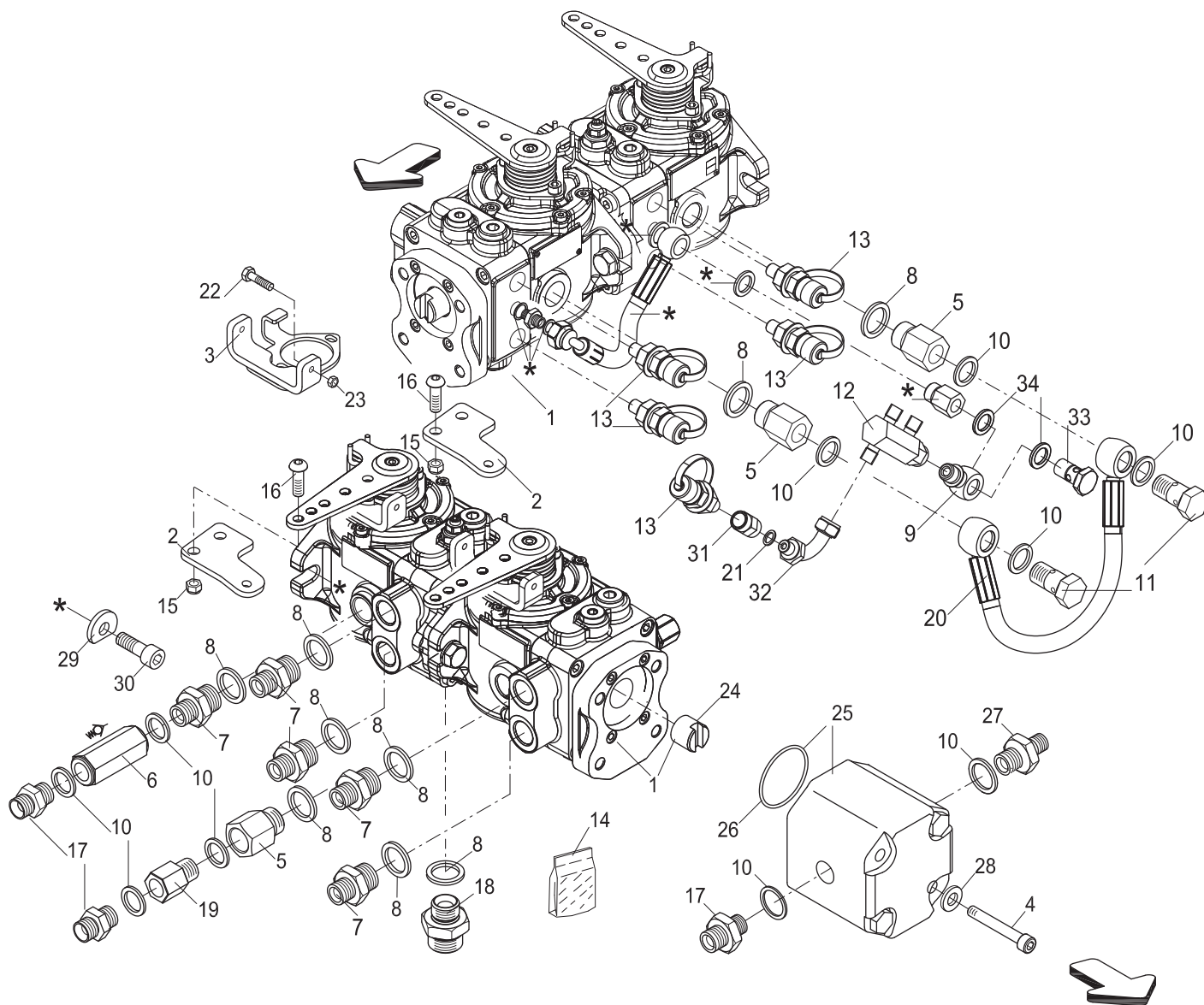

Hydraulic Pump Assembly Parts List

SECTION 4 PARTS

Item	Part #	Description	Qty.
1	065262	PUMP	1
2	25150273	CONTROL DEVICE	2
3	25150285	ADJUSTER	2
4	03235280	FSTN, SCREW M8x80 8.8	2
5	13154200	CONNECTOR	3
6	13843001	VALVE	1
7	13153900	CONNECTOR	4
8	03160006	WASHER	9
9	03150303	CONNECTOR	1
10	03160902	WASHER	10
11	03150600	SCREW	2
12	03635007	CONNECTOR	1
13	13845200	CHECKING COUPLING	5
14	065261	KIT - SEALS	1
15	03365150	FSTN, NUT M8	4
16	03237702	FSTN, SCREW M8x25 8.8	4
17	13152800	JUNCTION	3
18	13154000	CONNECTOR	1
19	03621100	CONNECTOR	1
20	03123401	PIPE	1
21	03160900	WASHER	1
22	03220601	FSTN, SCREW M6x20 8.8	4
23	03364003	FSTN, NUT M6	4
24	03799600	JOINT	1
25	065263	PUMP	1
26	67490039	O.R. RING	1
27	13154010	REDUCTION	1
28	03385000	WASHER, 8,1x14,2x2	2
29	45071165	WASHER, 10,5x28x4	2
30	03244902	FSTN, SCREW M10x30 12.9	2
31	03620202	CONNECTOR	1
32	03600009	ELBOW	1

SECTION 4 PARTS

Hydraulic Cooler Assembly Illustration

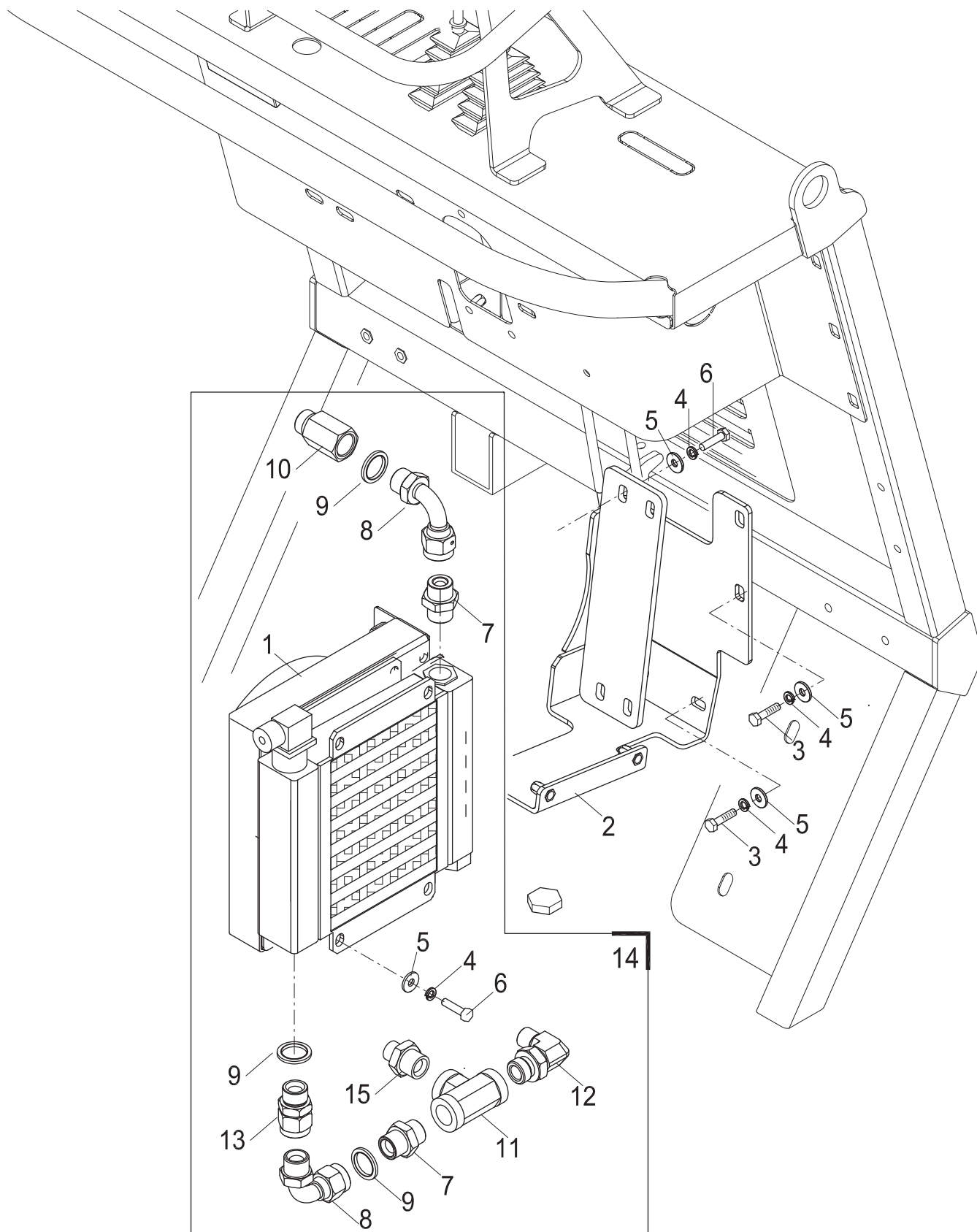

Hydraulic Cooler Assembly Parts List

SECTION 4 PARTS

<i>Item</i>	<i>Part #</i>	<i>Description</i>	<i>Qty.</i>
1	33840908	RADIATOR	1
2	45155465	SUPPORT	1
3	03220701	FSTN, SCREW M6x25 8.8	4
4	03383000	WASHER, 6,1x11,1x1,6	10
5	03383311	WASHER, 6,6x18x2	10
6	03220601	FSTN SCREW M6x20 8.8	4
7	13152900	JUNCTION	2
8	03606000	ELBOW	2
9	03160006	WASHER	3
10	03628100	CONNECTOR	1
11	03639800	JUNCTION	1
12	13161211	CONNECTOR	1
13	13152600	JUNCTION	1
14	98080006	KIT RADIATOR	1
15	13153900	JUNCTION	1

SECTION 4 PARTS

Fuel Tank Assembly Illustration

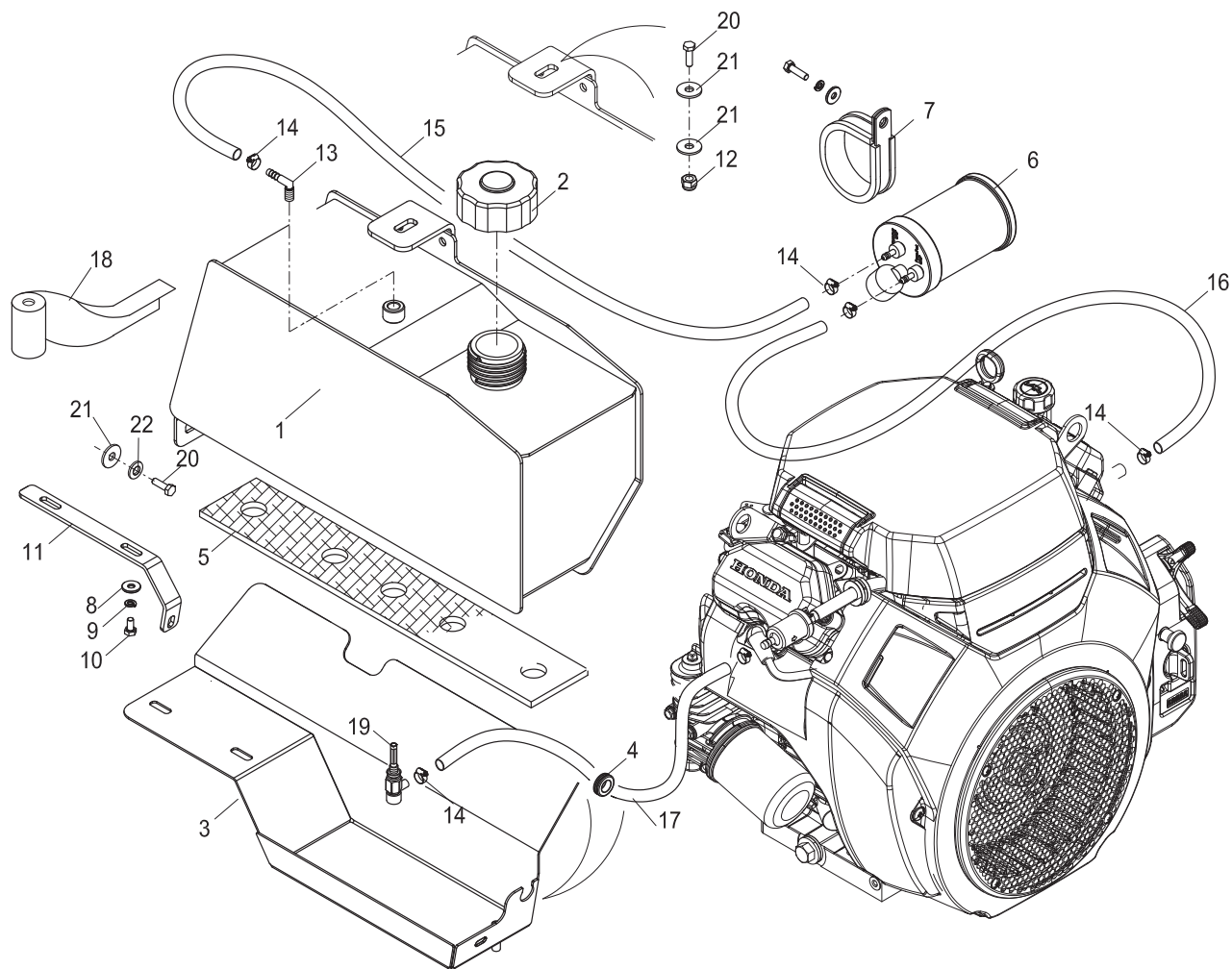

Fuel Tank Assembly Parts List

SECTION 4 PARTS

<i>Item</i>	<i>Part #</i>	<i>Description</i>	<i>Qty.</i>
1	15101393	FUEL TANK	1
2	13009606	PLUG	1
3	15101405	PANEL	1
4	03480021	FAIRLEAD	1
5	30322212	PANEL	1
6	13009605	CARBON CANISTER	1
7	13572444	COLLAR	1
8	03383311	WASHER	2
9	03383000	WASHER, 6,1x11,1x1,6	2
10	03220200	FSTN, SCREW M6x12 8.8	2
11	15101425	PLATE	1
12	03365100	FSTN, NUT M8	3
13	33140028	CONNECTOR	1
14	13577901	CLAMP	6
15	25170177	PIPE, 4.7x 11.1 L.650	1
16	25170176	PIPE, 11.1x 22.2 L.800	1
17	25170178	PIPE, 6.3x 12.7 L.450	1
18	20051354	ADHESIVE TAPE	1
19	13008905	TAP	1
20	03230601	FSTN, SCREW M8x25 8.8	3
21	03385401	WASHER, 8,4x24x2	4
22	03385050	WASHER	2

SECTION 4 PARTS

Wiring Assembly Illustration

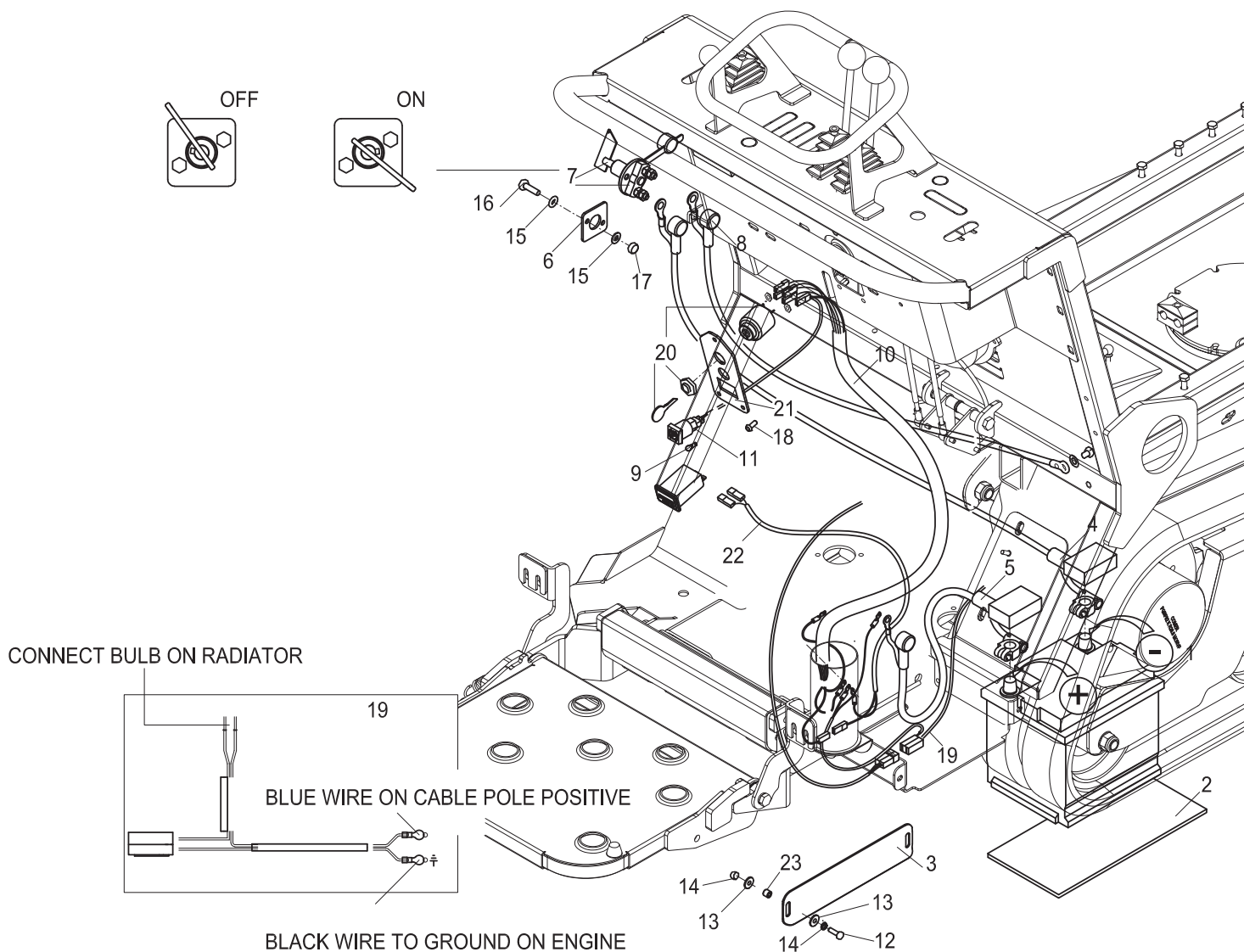

Wiring Assembly Parts List

SECTION 4 PARTS

<i>Item</i>	<i>Part #</i>	<i>Description</i>	<i>Qty.</i>
1	03010017	BATTERY	1
2	30013521	PROTECTION	1
3	45500258	CLAMP	1
4	60031668	NEGATIVE POLE CABLE	1
5	60031669	POSITIVE POLE CABLE	1
6	60020116	FLANGE	1
7	065264	BATTERY DISCONNECTING DEVICE	1
8	60031667	NEGATIVE POLE CABLE	1
9	03480601	LAMP	1
10	60031757	CABLE	1
11	33482061	WARNING LIGHT	1
12	03220602	FSTN, SCREW M6x20 A2	2
13	03383311	WASHER, 6,6x18x2	2
14	03383000	WASHER, 6,1x11,1x1,6	2
15	03364010	FSTN, NUT M6	4
16	03220701	FSTN, SCREW M6x25 8.8	2
17	03364010	FSTN, NUT M6	4
18	03227700	FSTN, SCREW M6x16 4.6	3
19	60031756	ELECTRIC SYSTEM	1
20	065265	STARTING SWITCH	1
21	60020128	PLATE	1
22	60031672	ELECTRIC SYSTEM	1
23	45020491	SPACER	2

SECTION 4 PARTS

Operator Console Assembly Illustration

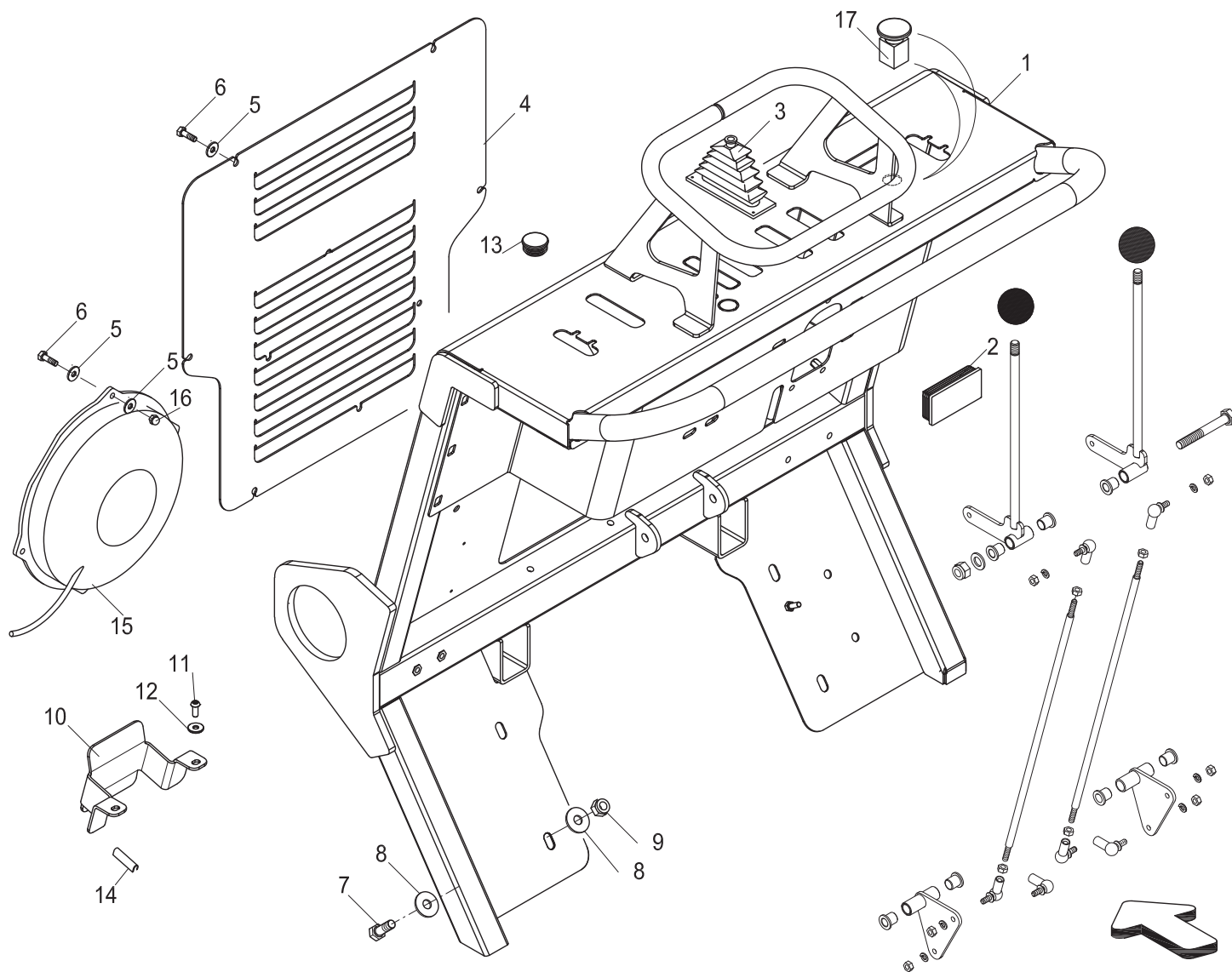

Operator Console Assembly Parts List

SECTION 4 PARTS

<i>Item</i>	<i>Part #</i>	<i>Description</i>	<i>Qty.</i>
1	55030821	FRAME - DRIVING PLACE	1
2	13480010	PLUG	1
3	065266	PROTECTION	3
4	30014950	PROTECTION	1
5	03383311	WASHER, 6,6x18x2	14
6	03227702	FSTN, SCREW M6x20 4.6	10
7	03240501	FSTN, SCREW M10x30 8.8	6
8	03386011	WASHER, 11x30x2,5	12
9	03366300	FSTN, NUT M10	6
10	30014864	CLAMP	1
11	03227700	FSTN, SCREW M6x16 4.6	2
12	03383311	WASHER, 6,6x18x2	2
13	13480200	PLUG	2
14	30014864	CLAMP	1
15	64844800	ELECTRIC FAN	1
16	03364010	FSTN, NUT M6	4
17	065274	PUSH BUTTON	1

SECTION 4 PARTS

Throttle Assembly Illustration

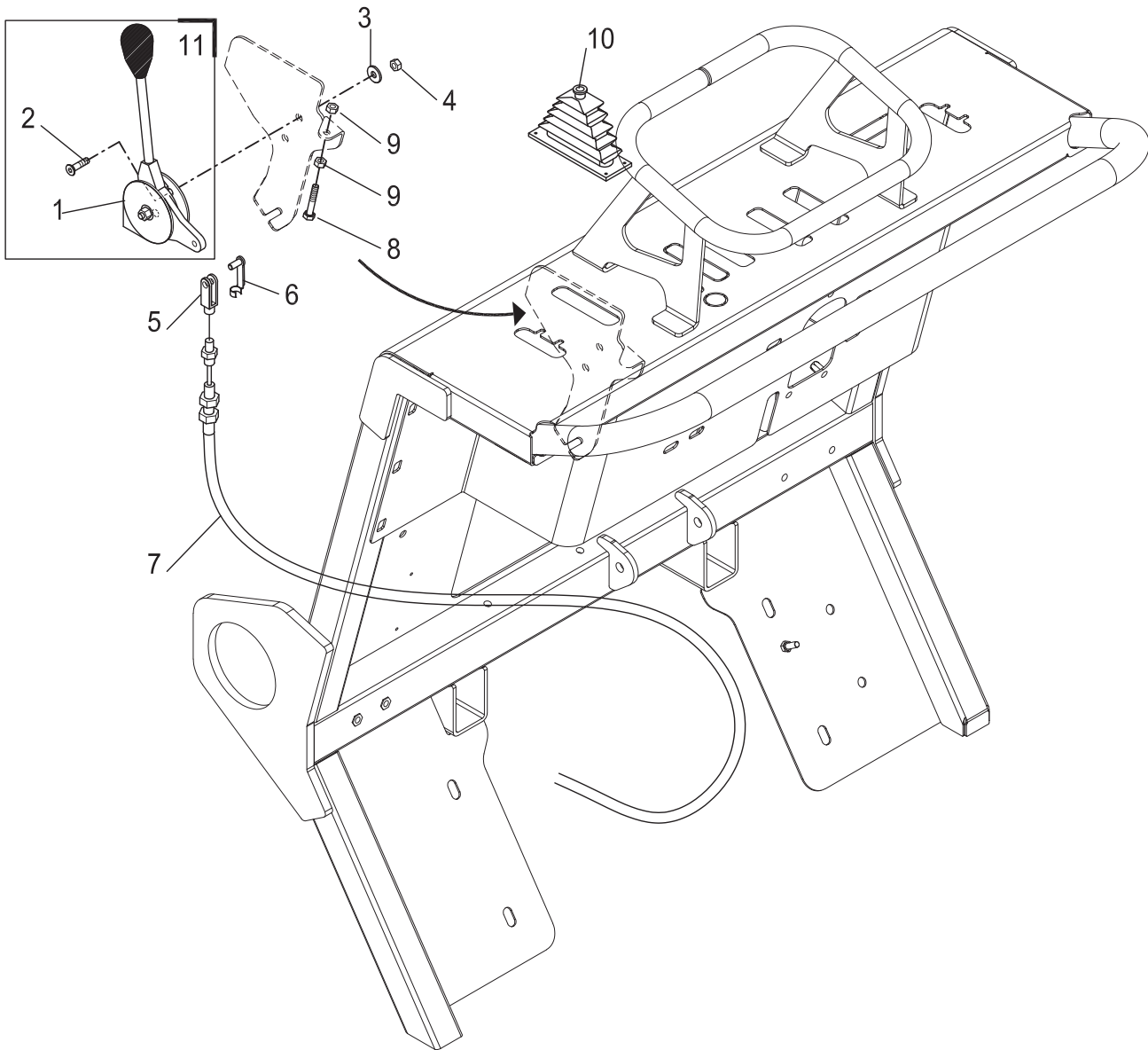

Throttle Assembly Parts List

SECTION 4 PARTS

<i>Item</i>	<i>Part #</i>	<i>Description</i>	<i>Qty.</i>
1	065267	HAND-LEVER	1
2	03227520	FSTN, SCREW M6x25 10.9	2
3	03383311	WASHER, 6,6x18x2	2
4	03364010	FSTN, NUT M6	2
5	13430001	FORK	1
6	13439570	PIN	1
7	065268	CABLE	1
8	03220901	FSTN, SCREW M6x35 8.8	1
9	03364001	FSTN, NUT M6 (5588)	2
10	065266	PROTECTION	1
11	98080007	KIT HAND-LEVER	1

SECTION 4 PARTS

Control Lever Assembly Illustration

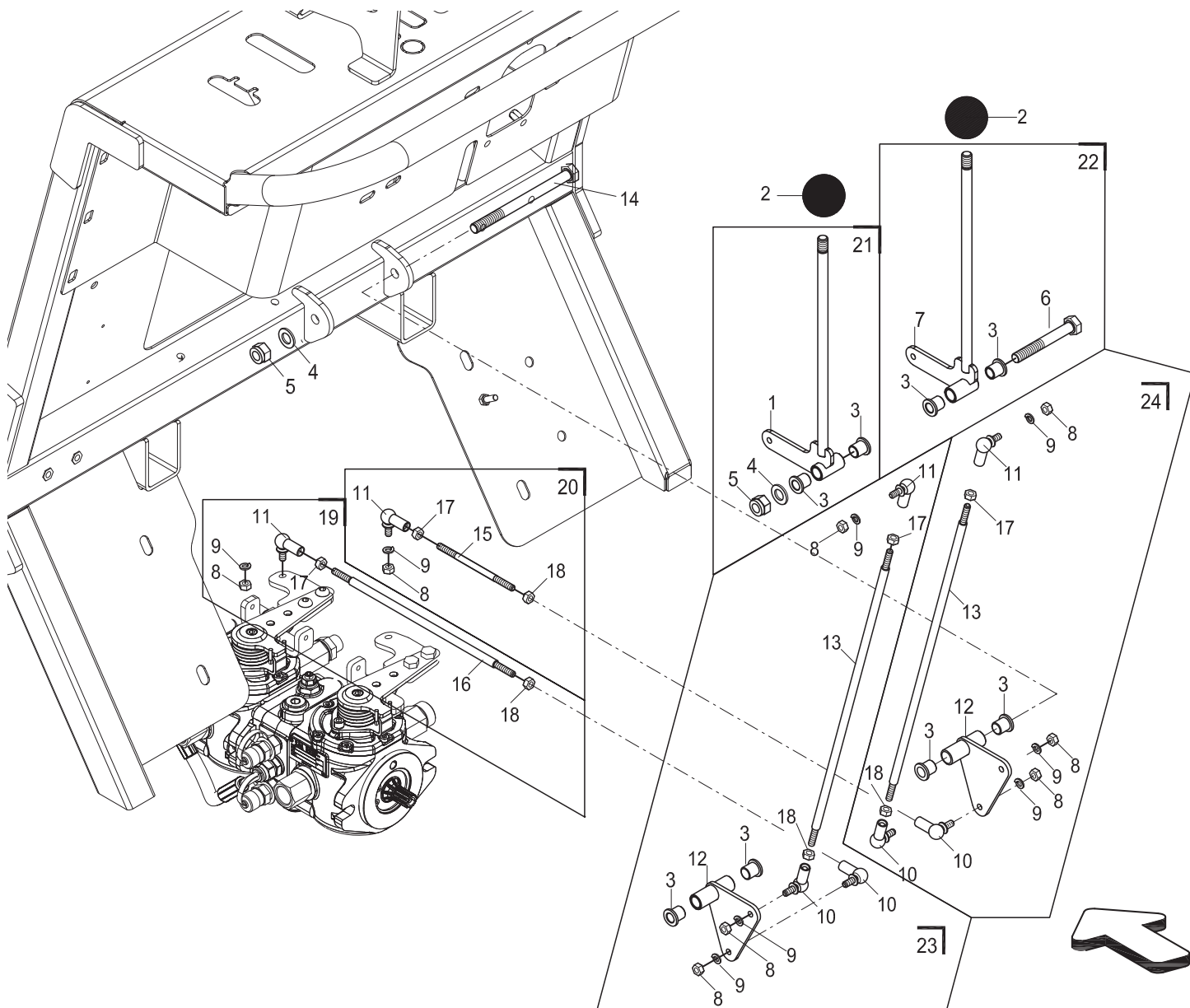

Control Lever Assembly Parts List

SECTION 4 PARTS

<i>Item</i>	<i>Part #</i>	<i>Description</i>	<i>Qty.</i>
1	23150293	COMPLETE LEVER	1
2	03581202	HANDGRIP	2
3	33592601	BUSH	8
4	03386201	WASHER, 10,5x21x2	2
5	03366300	FSTN, NUT M10	2
6	03241700	FSTN, SCREW M10x100 8.8	1
7	23150292	COMPLETE LEVER	1
8	03364010	FSTN, NUT M6	8
9	03383000	WASHER, 6,1x11,1x1,6	8
10	03554001	LEFT ARTICULATION	4
11	03554000	ARTICULATION	4
12	50101182	CONNECTING ROD	2
13	50101184	CONTROL LEVER	2
14	03242000	FSTN, SCREW M10x130 8.8	1
15	50101241	TIE ROD	1
16	50101240	TIE ROD	1
17	03364001	FSTN, NUT M6 (5588)	4
18	03364002	LEFT NUT	4
19	98080008	KIT - LINK ROD	1
20	98080009	KIT - LINK ROD	1
21	98080012	TRAVEL LEVER	1
22	98080013	TRAVEL LEVER	1
23	98080010	KIT - LINK ROD	1
24	98080011	KIT - LINK ROD	1

SECTION 4 PARTS

Control Lever Assembly Illustration

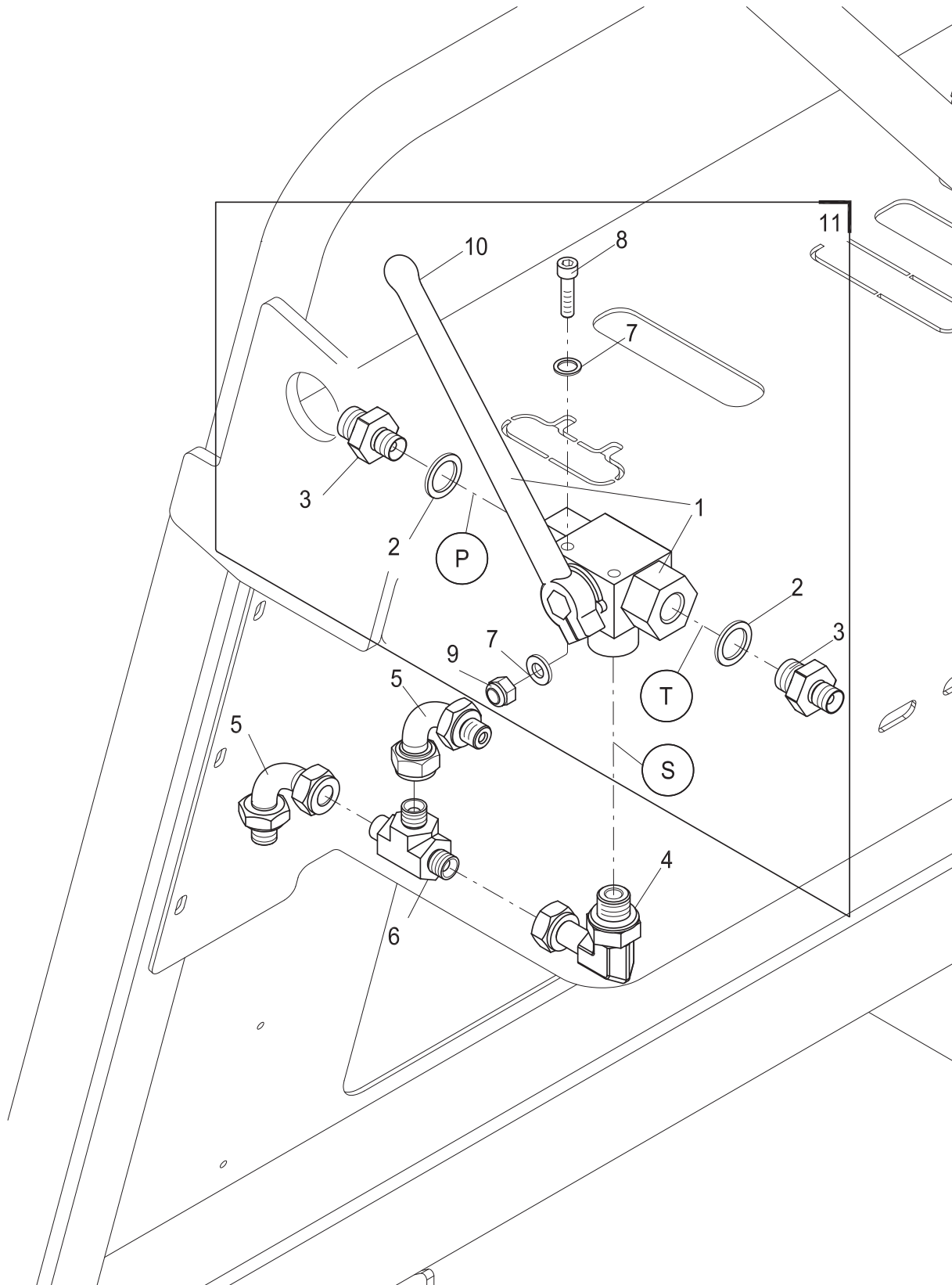

Control Lever Assembly Parts List

SECTION 4 PARTS

Item	Part #	Description	Qty.
1	13840026	TAP	1
2	03168500	GASKET	2
3	13150036	CONNECTOR	2
4	13161234	CONNECTOR	1
5	03600009	ELBOW	2
6	03630302	JUNCTION	1
7	03381000	WASHER, 5,3x10x1	4
8	03214600	FSTN, SCREW M5x45 8.8	2
9	03363001	FSTN, NUT M5	2
10	63840000	LEVER	1
11	98080015	KIT LEVER	1

SECTION 4 PARTS

Block Drainages and Servos Illustration

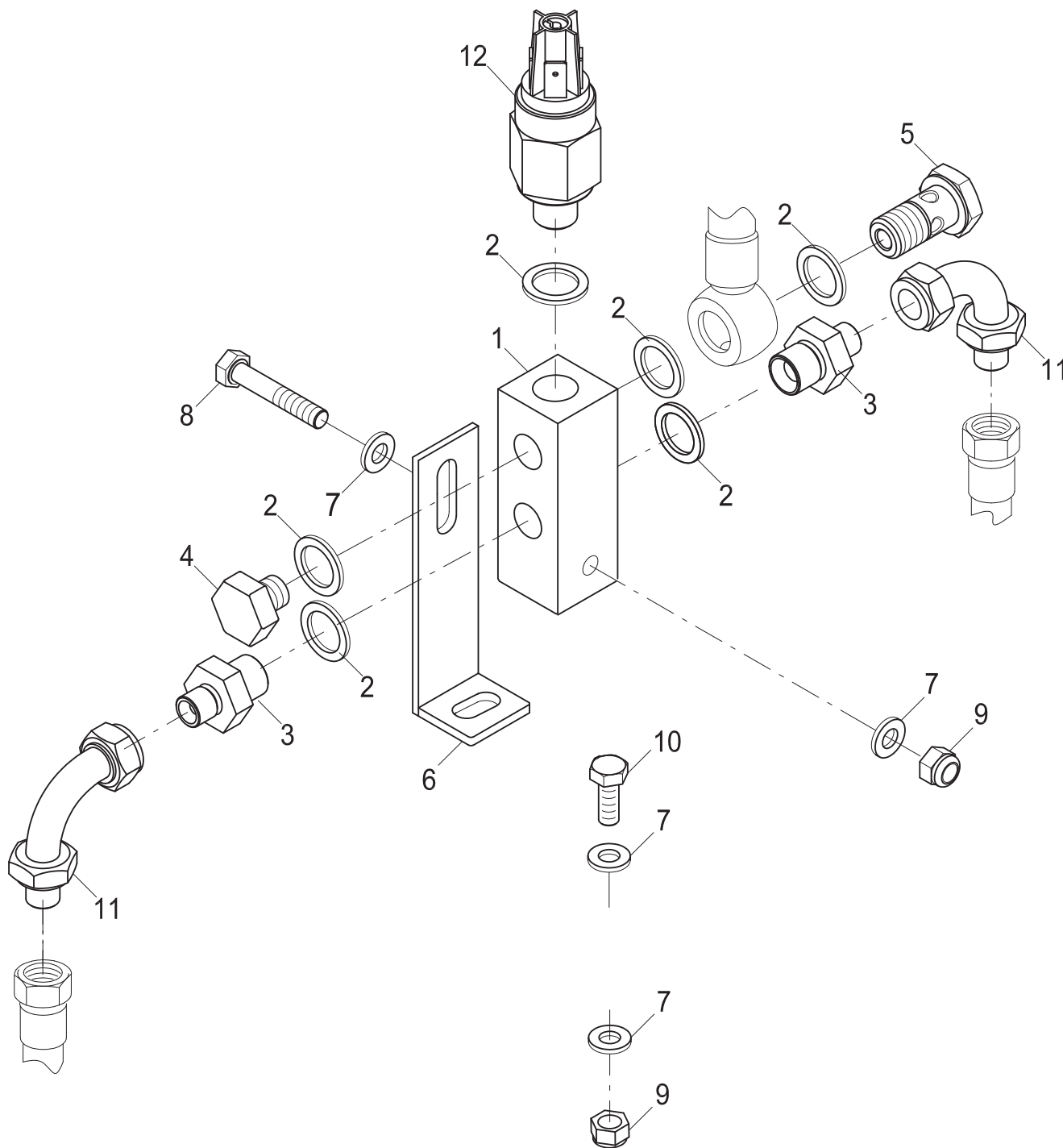

Block Drainages and Servos Parts List

SECTION 4 PARTS

Item	Part #	Description	Qty.
1	25200650	CONNECTOR	1
2	03160901	WASHER	6
3	13150036	CONNECTOR	2
4	13166010	PLUG	1
5	03150006	SCREW	1
6	45500134	SUPPORT	1
7	03383202	WASHER, 6,4x12,5x1,6	4
8	03220901	FSTN, SCREW M6x35	1
9	03364010	FSTN, NUT M6	2
10	03220401	FSTN, SCREW M6x16 8.8	1
11	03600009	ELBOW	2
12	03841606	SWITCH	1

SECTION 4 PARTS

Hood Assembly Illustration

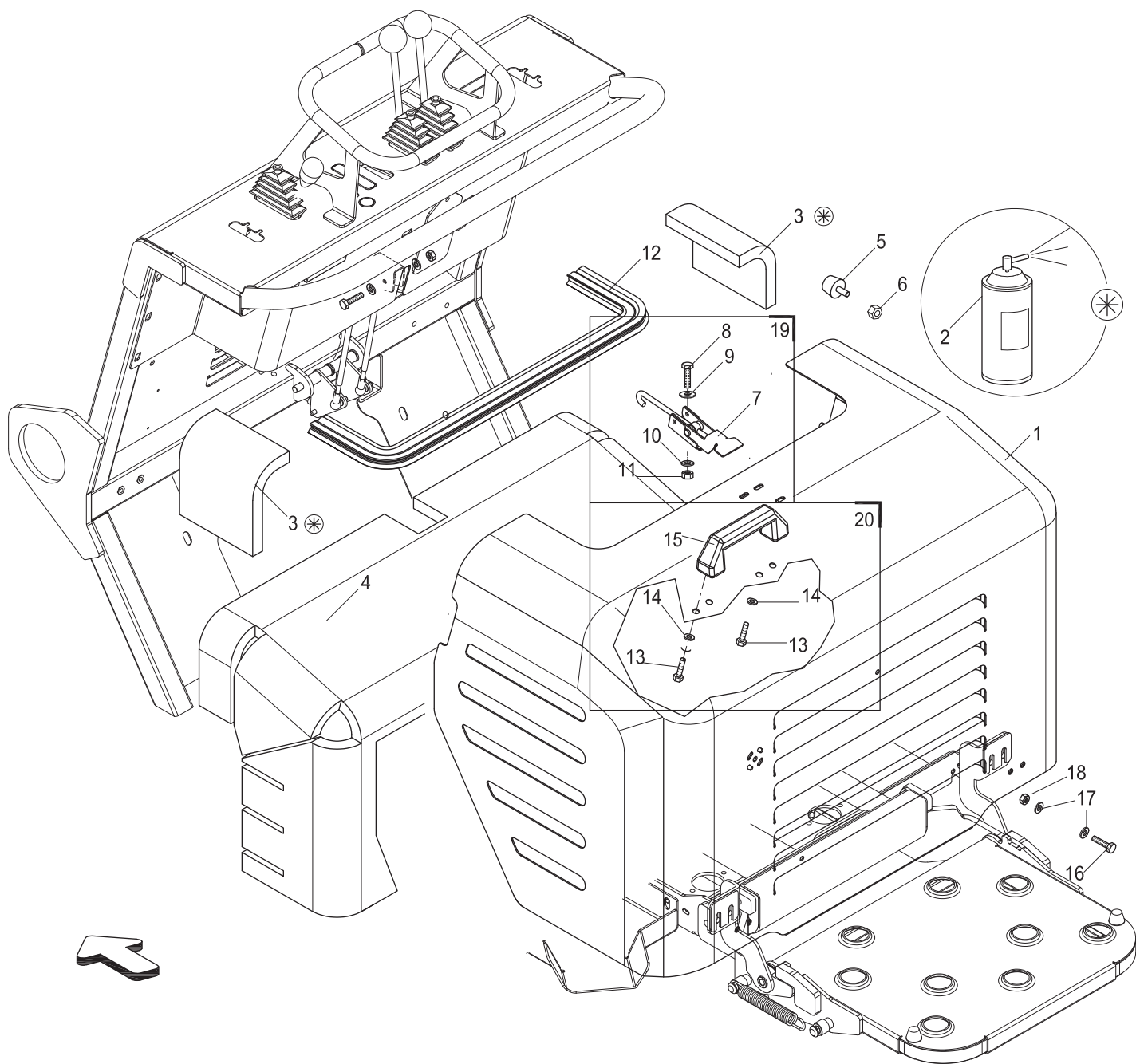

Hood Assembly Parts List

SECTION 4 PARTS

Item	Part #	Description	Qty.
1	30014900	HOOD	1
2	03709010	ADHESIVE	2
3	065331	ISOLATION	2
4	065332	PANEL	1
5	03529600	VIBRATION-DAMPING	2
6	03364001	FSTN, NUT M6	2
7	065269	LOCKING	1
8	03220601	FSTN, SCREW M6x20 8.8	2
9	03383201	WASHER, 6,4x12,5x1,6	2
10	03383311	WASHER, 6,6x18x2	2
11	03364010	FSTN, NUT M6	2
12	065335	GASKET	1
13	03230501	FSTN, SCREW M8x20 8.8	2
14	03385601	WASHER, 9x24x2	2
15	03580100	HANDLE	1
16	03230501	FSTN, SCREW M8x20 8.8	4
17	03385600	WASHER, 8,4x17x1,6	8
18	03365100	FSTN, NUT M8	4
19	065333	KIT-LOCKING	1
20	065334	KIT HANDLE	1

SECTION 4 PARTS

Bucket Valve Fitting Assembly Illustration

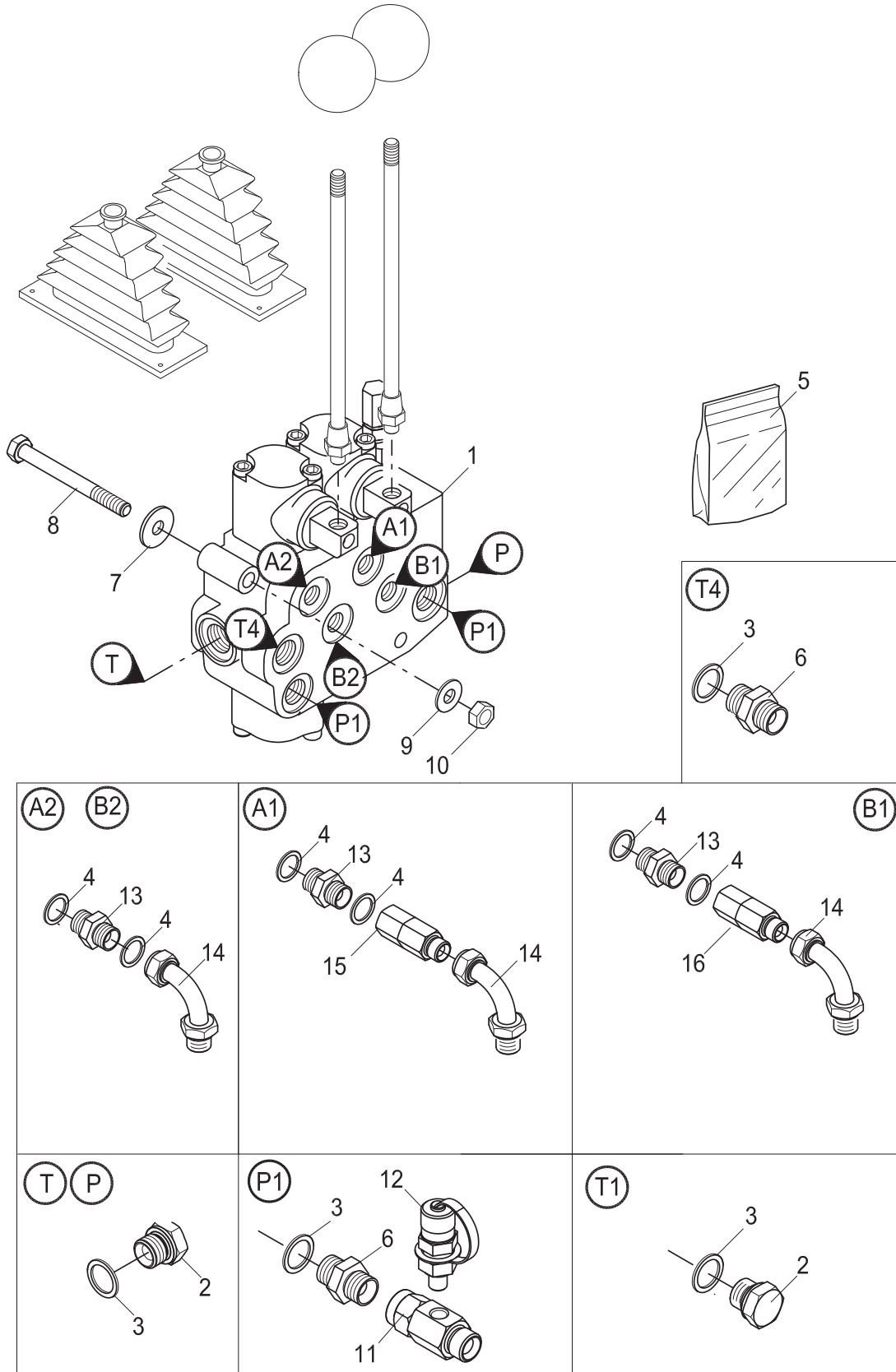

Bucket Valve Fitting Assembly Parts List

SECTION 4 PARTS

Item	Part #	Description	Qty.
1	13180503	DISTRIBUTOR	1
2	13160013	PLUG	3
3	03160902	WASHER	5
4	03160901	WASHER	4
5	065270	KIT SEALS	1
6	13152800	JUNCTION	2
7	03385401	WASHER	2
8	03231301	FSTN, SCREW M8x60 8.8	2
9	03385201	WASHER, 8,4x17x1,6	2
10	03365100	FSTN, NUT M8	2
11	25200603	CONNECTOR	1
12	13845200	CHECKING COUPLING	1
13	13152700	JUNCTION	4
14	03605800	ELBOW	4
15	13843506	THROAT	1
16	13843507	VALVE	1

SECTION 4 PARTS

Hydraulic Hose Assembly Illustration

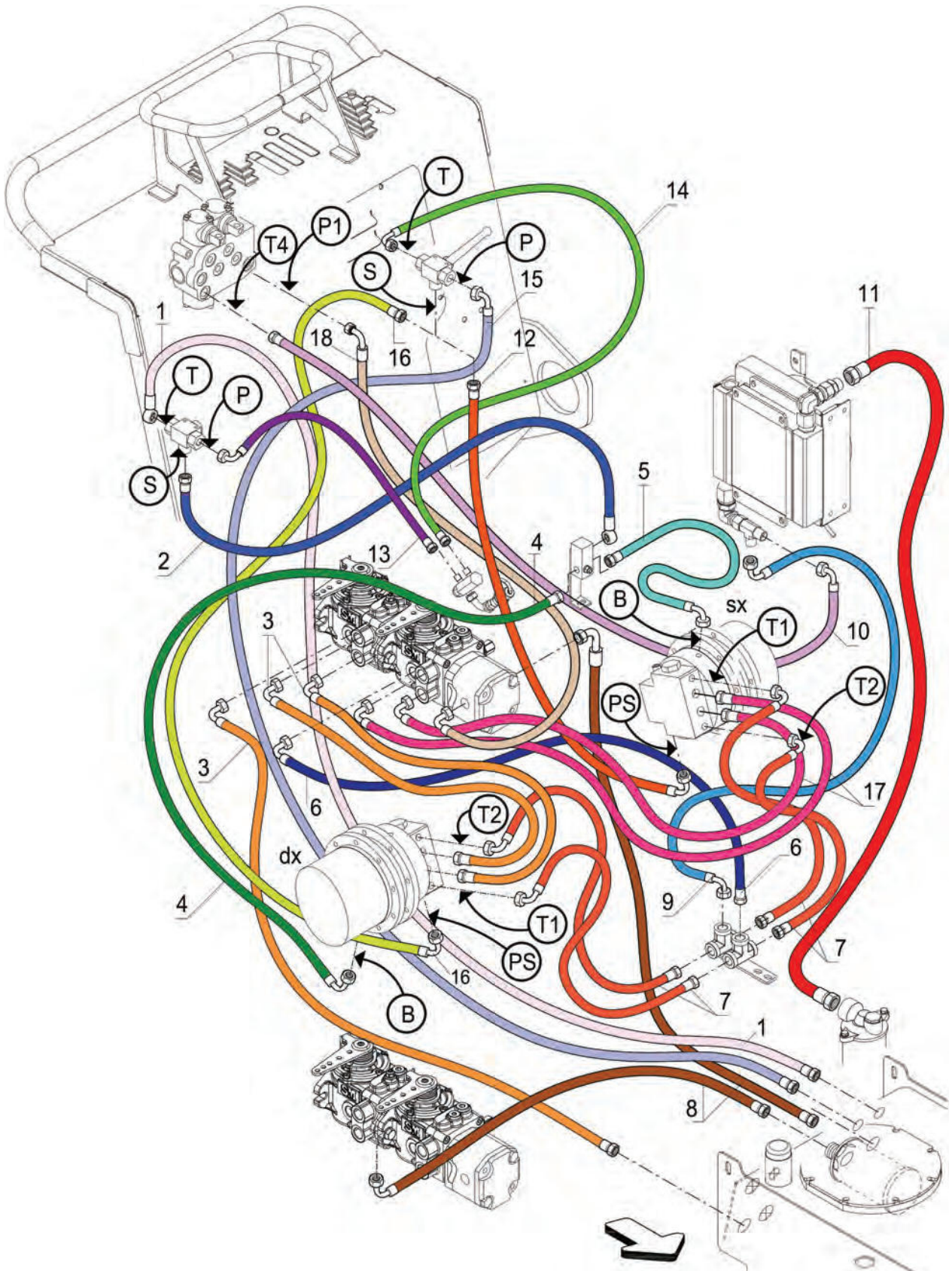

Hydraulic Hose Assembly Parts List

SECTION 4 PARTS

Item	Part #	Description	Qty.
1	03122034	HOSE, 59" 3/16DIA FEMALE 1/4" BSPP- FEMALE 1/8" BSPP	1
2	03122031	HOSE, 39.3" 3/16DIA FEMALE 1/4" BSPP- FEMALE 1/8" BSPP	1
3	03111933	HOSE, 17.7" 3/16DIA FEMALE 3/8" - FEMALE 3/8" 90° BSPP	3
4	03121890	HOSE, 51.1" 3/16DIA FEMALE 3/16" - FEMALE 1/8" 90° BSPP	1
5	03121868	HOSE, 31.5" 3/16DIA FEMALE 3/16" - FEMALE 1/8" 90° BSPP	1
6	03111845	HOSE, 13.7" 3/8DIA FEMALE 3/8" - FEMALE 3/8" 90° BSPP	1
7	03121913	HOSE, 70.8" 3/8DIA FEMALE 3/8" - FEMALE 3/8" 90° BSPP	4
8	03130021	HOSE, 23.6" 3/4DIA FEMALE 3/4" - FEMALE 3/4 90° BSPP	2
9	03111963	HOSE, 27.5" 3/8DIA FEMALE 3/8" - FEMALE 3/8" 90° BSPP	1
10	03111959	HOSE, 43.3" 3/8DIA FEMALE 3/8" - FEMALE 3/8" 90° BSPP	1
11	03111918	HOSE, 45.2" 1/2DIA FEMALE 1/2" - FEMALE 1/2" 90° BSPP	1
12	03121880	HOSE, 47.2" 3/16DIA FEMALE 1/8" - FEMALE 1/4" 90° BSPP	1
13	03121890	HOSE, 51.1" 3/16DIA FEMALE 3/16" - FEMALE 1/8" 90° BSPP	1
14	03121865	HOSE, 39.3" 3/16DIA FEMALE 3/16" - FEMALE 1/8" 90° BSPP	1
15	03121863	HOSE, 47.2" 3/16DIA FEMALE 3/16" - FEMALE 1/8" 90° BSPP	1
16	03121925	HOSE, 63" 3/16DIA FEMALE 1/8" BSPP - FEMALE 1/4" 90° BSPP	1
17	03111846	HOSE, 22.8" 3/8DIA FEMALE 3/8" - FEMALE 3/8" 90° BSPP	2
18	03123200	HOSE, 49.2" 3/8" FEMALE 3/8" 90° - FEMALE 3/8" 90° BSPP	1

SECTION 4 PARTS

Decal Assembly Illustration

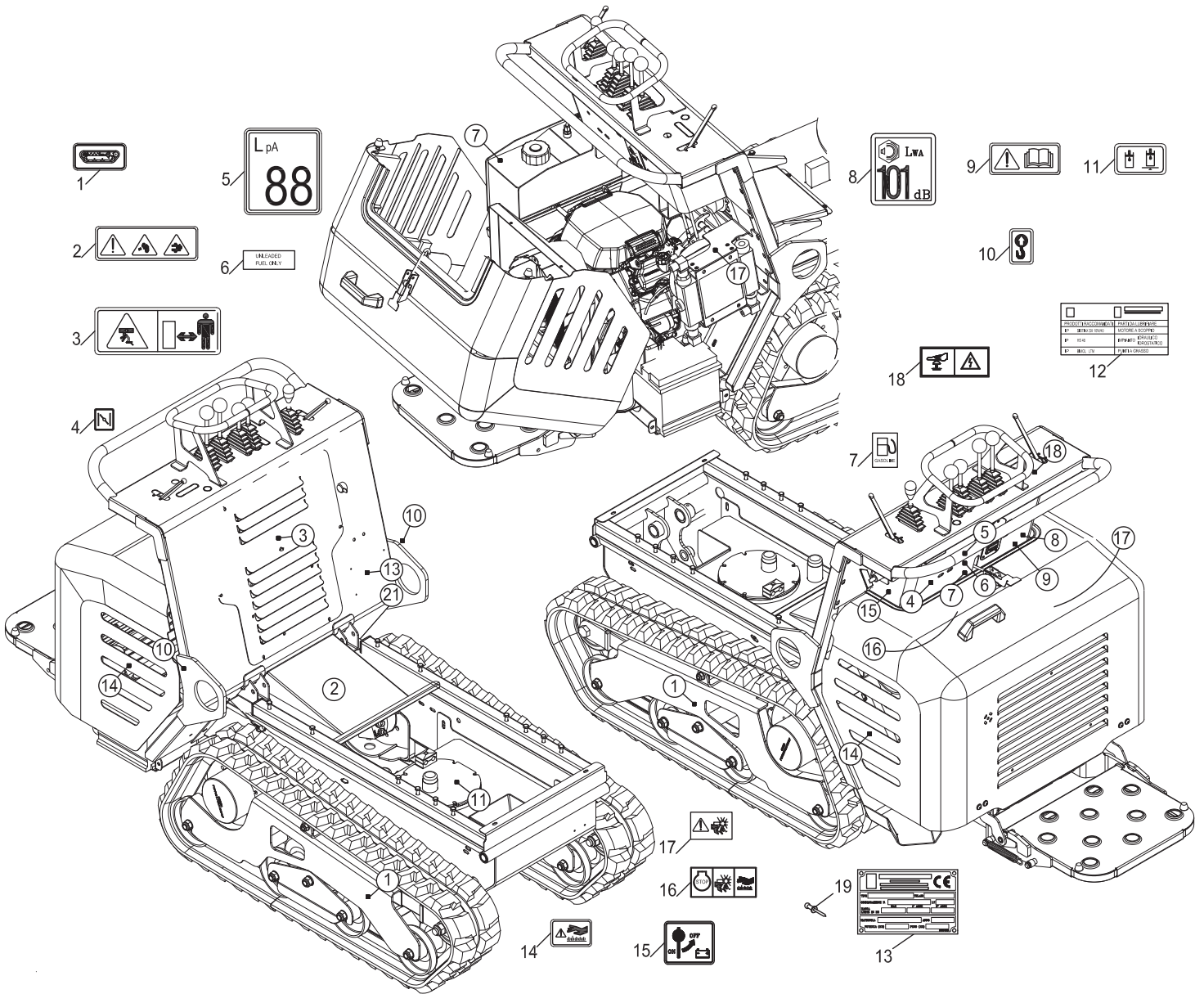

Decal Assembly Parts List

SECTION 4 PARTS

Item	Part #	Description	Qty.
1	03666063	DECAL, ADJUSTING VOLTAGE TRACK	2
2	03660099	DECAL, DANGER OF SHEARING	2
3	03660098	DECAL, DWELL IN ACTION	2
4	03660252	DECAL, STARTER	1
5	03665029	DECAL, LPA 88	1
6	03660177	DECAL, UNLEADED GASOLINE	1
7	03660230	DECAL, GASOLINE	1
8	03665022	DECAL, LWA 101	1
9	03660170	DECAL, REFER TO OPERATOR'S MANUAL	1
10	03666024	DECAL, LIFTING MACHINE	2
11	03666066	DECAL, HYDRAULIC	1
12	03664406	DECAL, LUBRICANT	1
13	03664801	SERIAL NUMBER LABEL	1
14	03660192	DECAL, BURN HAZARD	1
15	03660160	DECAL, ARM-DISARM BATTERY	1
16	03666312	DECAL, STOP ENGINE BEFORE OPENING THE HOOD	1
17	03660169	DECAL, DANGER ROTATING FAN	1
18	03664970	DECAL, PRESS THE BUTTON EMERGENCY BEFORE OPENING THE HOOD	1
19	03449900	RIVET	4

SECTION 4 PARTS

Decal Assembly Illustration (cont'd)

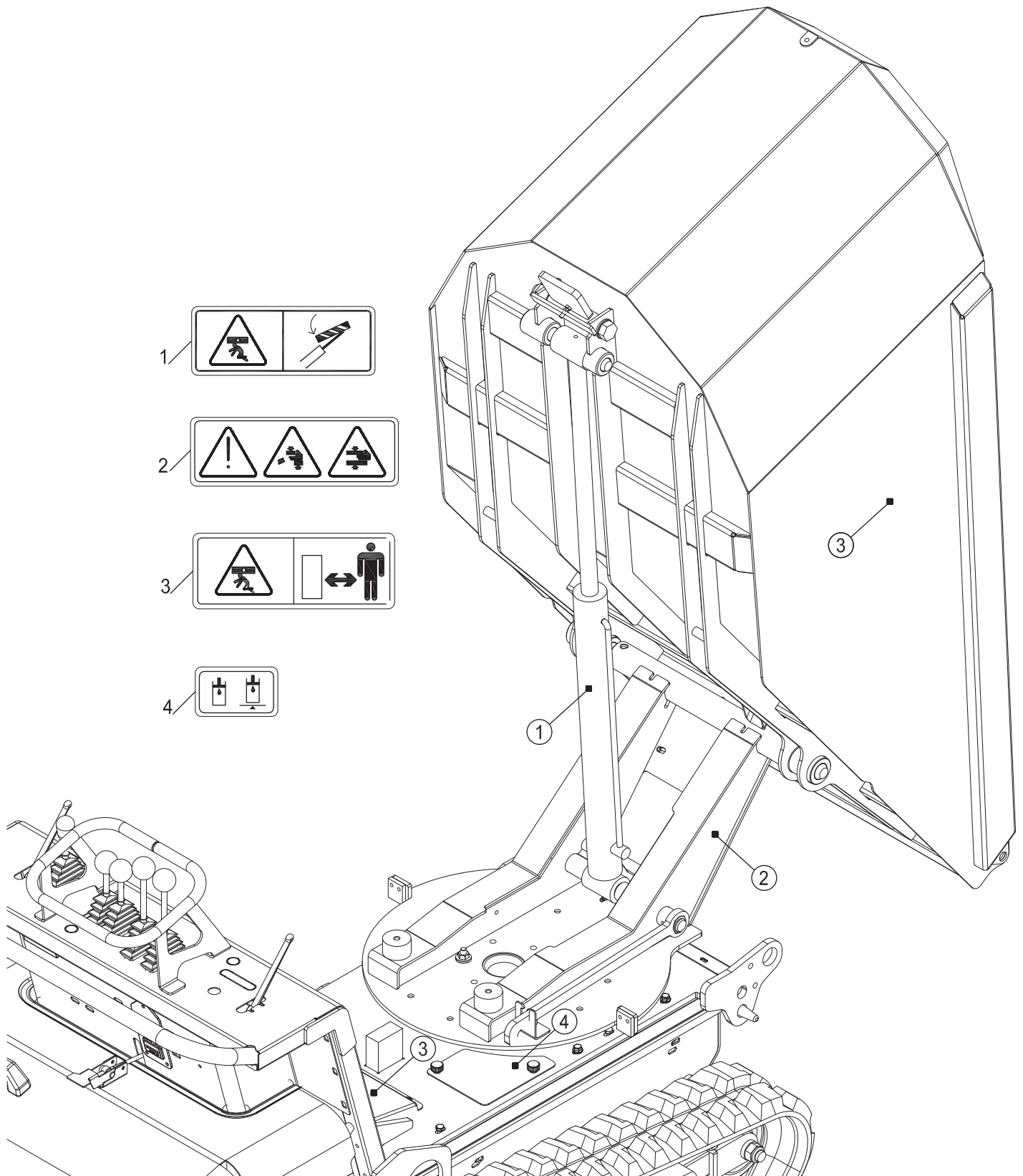

Decal Assembly Parts List (cont'd)

SECTION 4 PARTS

Item	Part #	Description	Qty.
1	03660062	DECAL, ENTERING FIXED POINT	1
2	03660099	DECAL, DANGER OF SHEARING	2
3	03660098	DECAL, DWELL IN ACTION	1
4	03666066	DECAL, HYDRAULIC	1

SECTION 4 PARTS

Maintenance Tools Illustration

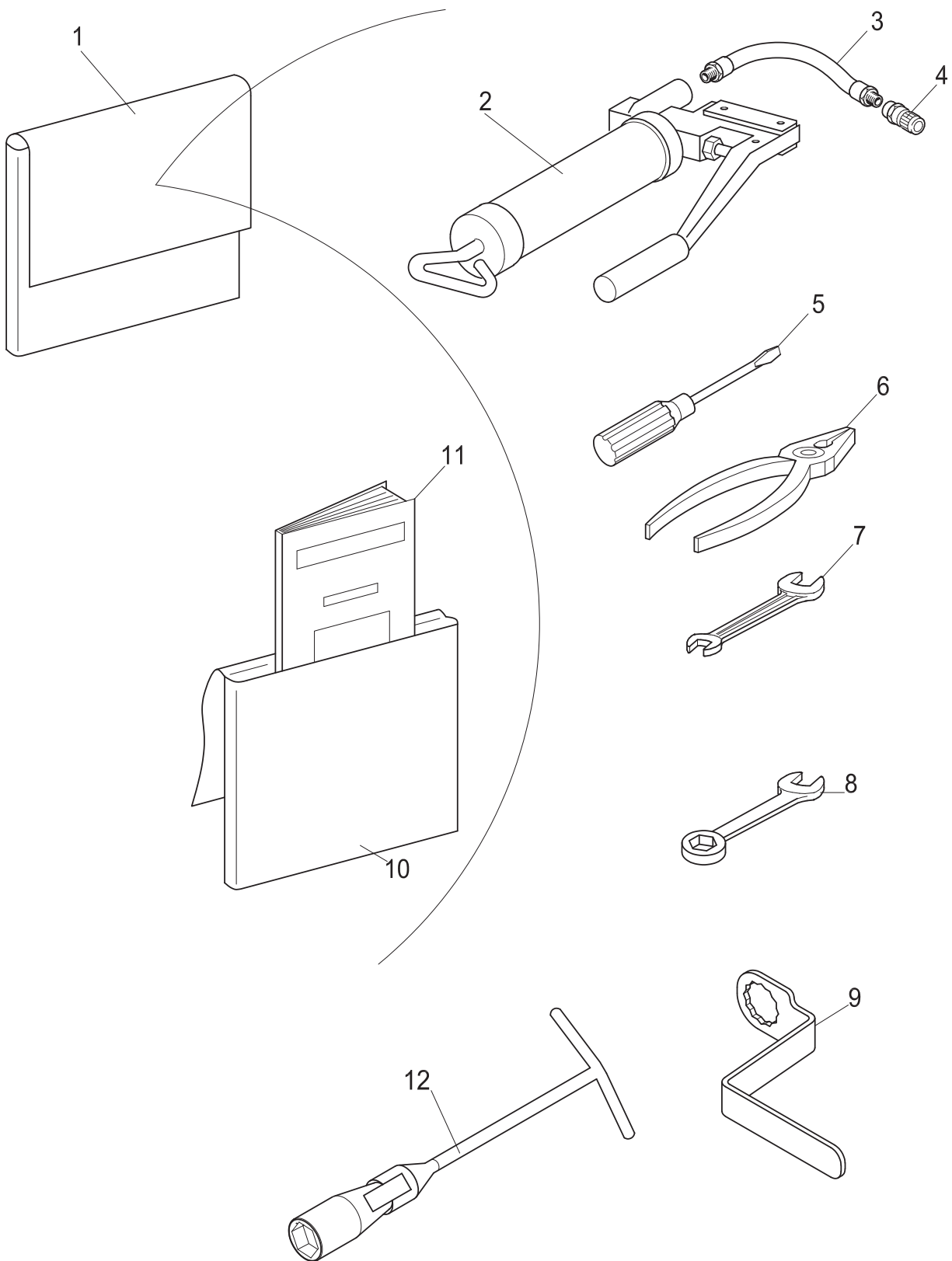

Maintenance Tools Parts List

SECTION 4 PARTS

Item	Part #	Description	Qty.
1	03679700	HOLDER	1
2	03519600	GREASING PUMP	1
3	03519800	PIPE	1
4	03519900	HEAD	1
5	03572000	SCREWDRIVER	1
6	03572300	NIPPER	1
7	03570000	KEY 10-13 mm	1
8	83130493	KEY	1
9	99100033	KEY	1
10	03679000	HOLDER	1
11	065300	PARTS CATALOG	1
12	03570403	KEY	1

SECTION 4 PARTS

Hourmeter Illustration

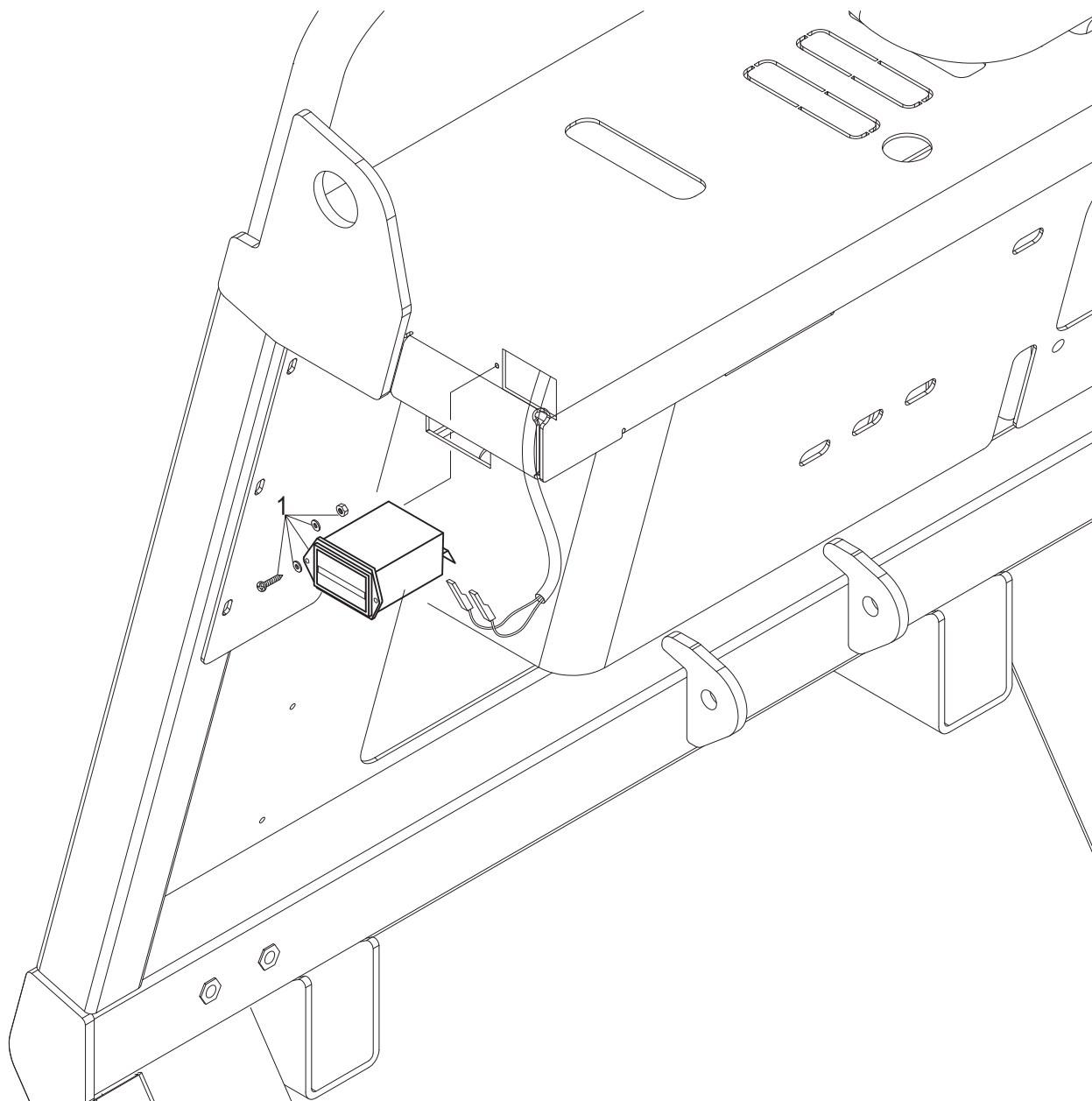

Hourmeter Parts List

SECTION 4 PARTS

Item	Part #	Description	Qty.
1	03484203	HOURMETER	1

SECTION 4 PARTS

Bucket Hydraulic Cylinder Assembly Illustration

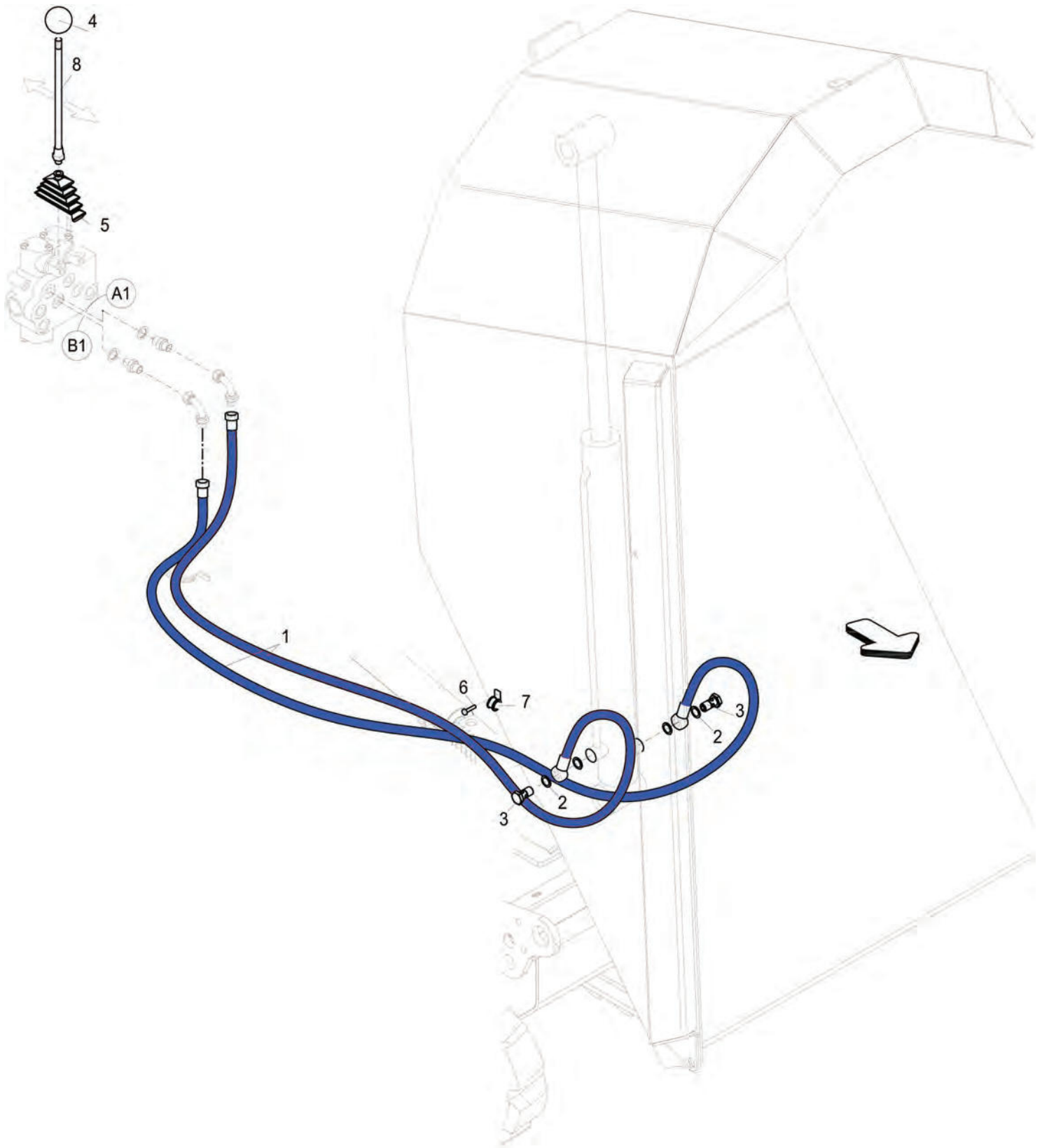

Bucket Hydraulic Cylinder Assembly Parts List

SECTION 4 PARTS

Item	Part #	Description	Qty.
1	03112148	HOSE, 106.2" 1/4DIA OCCH - FEMALE 1/4" BSPP	2
2	03160901	WASHER	4
3	03150006	SCREW	2
4	03581403	BALL	1
5	065266	PROTECTION	1
6	03220902	FSTN, SCREW M6x40 8.8	2
7	13572414	COLLAR	2
8	23150286	LEVER	1

SECTION 4 PARTS

Swivel Hydraulic Cylinder Assembly Illustration

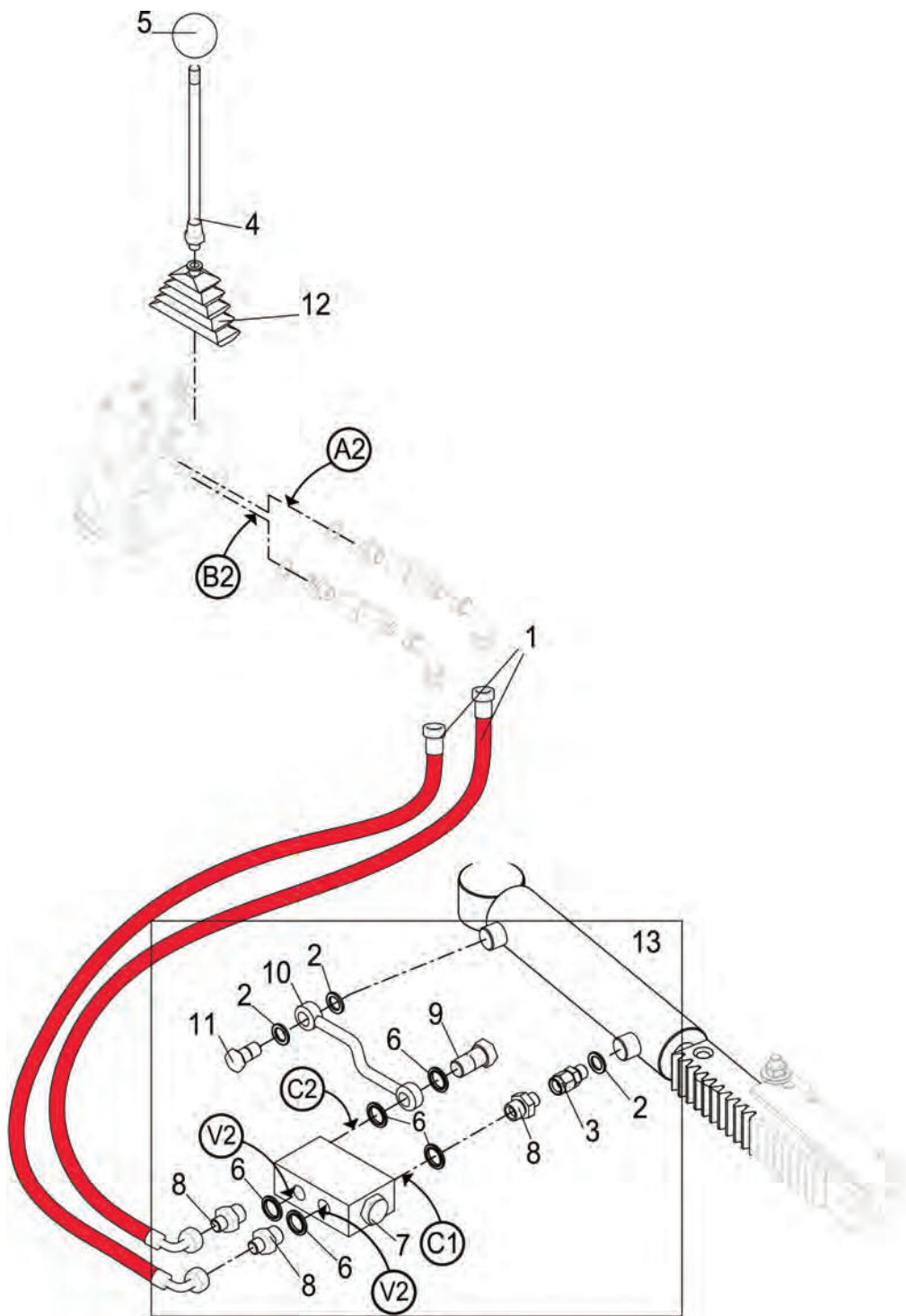

Swivel Hydraulic Cylinder Assembly Parts List

SECTION 4 PARTS

Item	Part #	Description	Qty.
1	03121440	HOSE, 82.6" 1/4DIA FEMALE 1/4" - FEMALE 1/4" 90° BSPP	2
2	03160901	WASHER	3
3	13150032	JUNCTION	1
4	23150233	LEVER	1
5	03581203	HANDGRIP	1
6	03160902	WASHER	5
7	13842203	VALVE	1
8	13153950	JUNCTION	3
9	03150600	SCREW	1
10	25160560	HOSE, RIGID FROM CYLINDER VALVE	1
11	03150006	SCREW	1
12	065266	PROTECTION	1
13	98190004	KIT VALVE	1

SECTION 4 PARTS

Trilateral Tipping Bucket Assembly Illustration

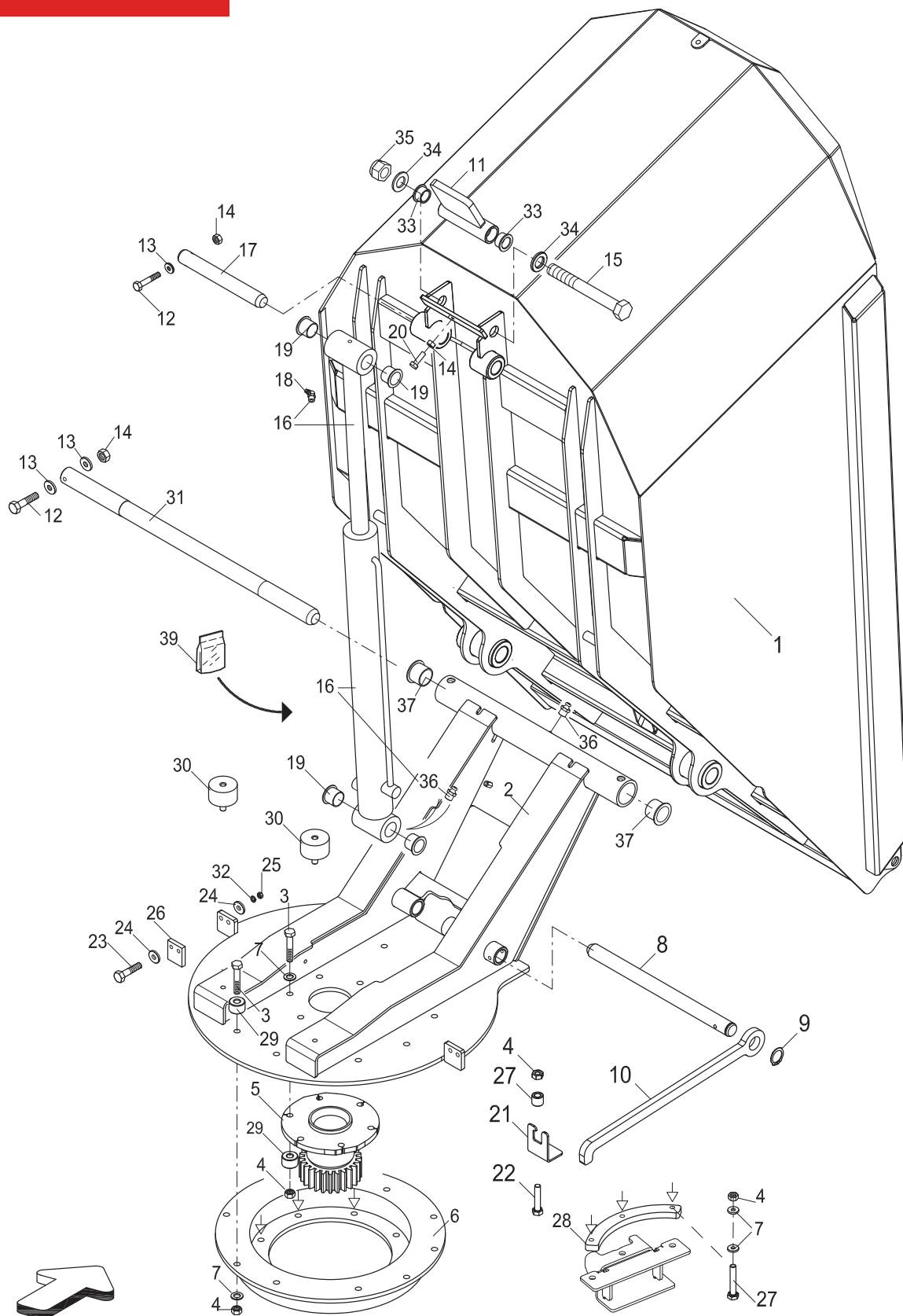

Trilateral Tipping Bucket Assembly Parts List

SECTION 4 PARTS

Item	Part #	Description	Qty.
1	10013188	SKIP	1
2	55020770	EVOLUTION FRAME	1
3	03241000	FSTN, SCREW M10x55 10.9	16
4	03366001	FSTN, NUT M10	1
5	065271	PINION	1
6	45030115	BEARING DISK	1
7	03386300	WASHER, 10,5x28x4	12
8	45071354	PIN	1
9	03429700	STOP RING	1
10	10013190	PIN	1
11	23100251	PIN	1
12	03221400	FSTN, SCREW M6x60 8.8	1
13	03383201	WASHER	2
14	03364010	NUT	4
15	03284400	SCREW	1
16	065272	CYLINDER	1
17	45071315	PIN	1
18	03511120	LUBRICATOR	1
19	33593618	BUSH	4
20	03220700	SCREW	1
21	10013191	PIN	1
22	03240901	SCREW	1
23	03220800	SCREW	4
24	03383311	WASHER	8
25	03364010	NUT	4
26	45250025	RABBET	2
27	45020491	SPACER	1
28	55020771	FLANGE	1
29	45020491	SPACER	19
30	03520300	VIBRATION-DAMPING	2
31	45071314	PIN	1
32	03383311	WASHER	4
33	33592604	BUSH	2
34	03390710	WASHER	2
35	03371101	NUT	1
36	03511100	LUBRICATOR	1
37	33593670	BUSH	2
38	03383000	WASHER	2
39	62499875	KITSEALS	1

SECTION 4 PARTS

Trilateral Tipping Bucket Assembly Illustration (cont'd)

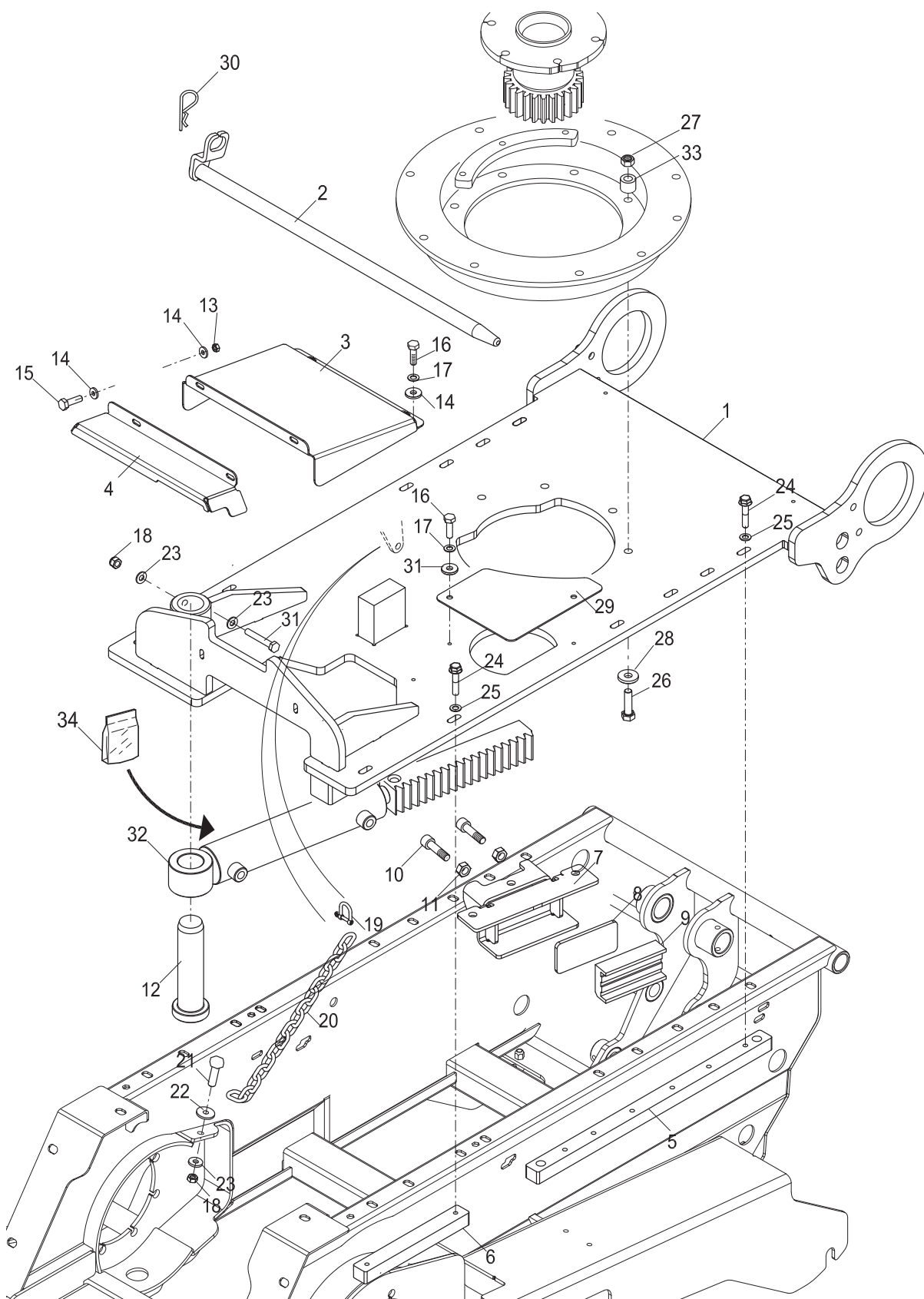

Trilateral Tipping Bucket Assembly Parts List (cont'd)

SECTION 4 PARTS

Item	Part #	Description	Qty.
1	10013194	STEADY FRAME	1
2	45070937	PIN	1
3	30014830	CRANKCASE	1
4	30014831	CRANKCASE	1
5	55081584	PLATE	2
6	55081657	PLATE	2
7	45155438	SUPPORT	1
8	45155439	PLATE	1
9	45300076	GUIDE BLOCK	1
10	03245101	FSTN, SCREW M10x40 8.8	2
11	03366001	FSTN, NUT M10	2
12	45071316	PIN	1
13	03364004	FSTN, NUT M6	2
14	03383300	WASHER, 6,4x18x1	6
15	03220800	FSTN, SCREW M6x30 8.8	2
16	03220401	FSTN, SCREW M6x16 8.8	4
17	03383000	WASHER, 6,4x18x1	4
18	03365100	FSTN, NUT M8	2
19	03350007	CONNECTION	1
20	45155466	CHAIN	1
21	03230701	FSTN, SCREW M8x30 8.8	1
22	03385401	WASHER, 8,4x24x2	1
23	03385201	WASHER, 8,4x17x1,6	3
24	03230511	FSTN, SCREW M8x40 8.8	12
25	03572040	WASHER, 8.4x16.6x2.29	12
26	03241000	FSTN, SCREW M10x55 10.9	5
27	03366300	FSTN, NUT M10	5
28	03386201	WASHER, 10,5x21x2	5
29	10012918	DOOR	1
30	03739800	SPLIT PIN	1
31	03231501	FSTN, SCREW M8x70 8.8	1
32	065273	CYLINDER	1
33	45020491	SPACER	5
34	62499876	KITSEALS	1

SECTION 4 PARTS

Trilateral Tipping Bucket Assembly Illustration (cont'd)

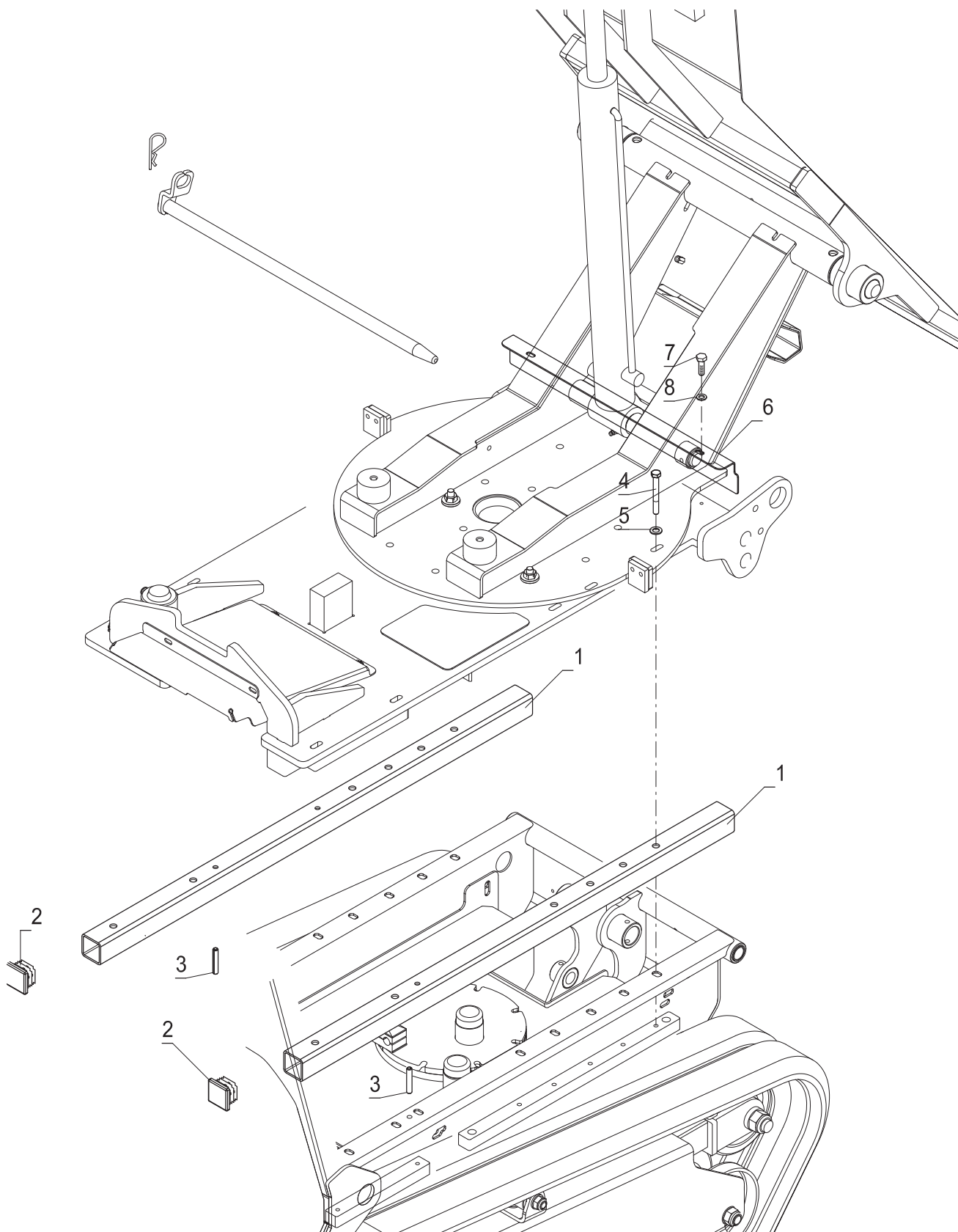

Trilateral Tipping Bucket Assembly Parts List (cont'd)

SECTION 4 PARTS

Item	Part #	Description	Qty.
1	10013152	SUPPORT	2
2	13480217	PLUG	2
3	03400602	PIN	2
4	03231501	FSTN, SCREW M8x70 8.8	12
5	03572040	WASHER, 8.4x16.6x2.29	12
6	10013151	CRANKCASE	1
7	03220401	FSTN, SCREW M6x16 8.8	2
8	03383201	WASHER, 6,4x12,5x1,6	2

Hydraulic Schematic

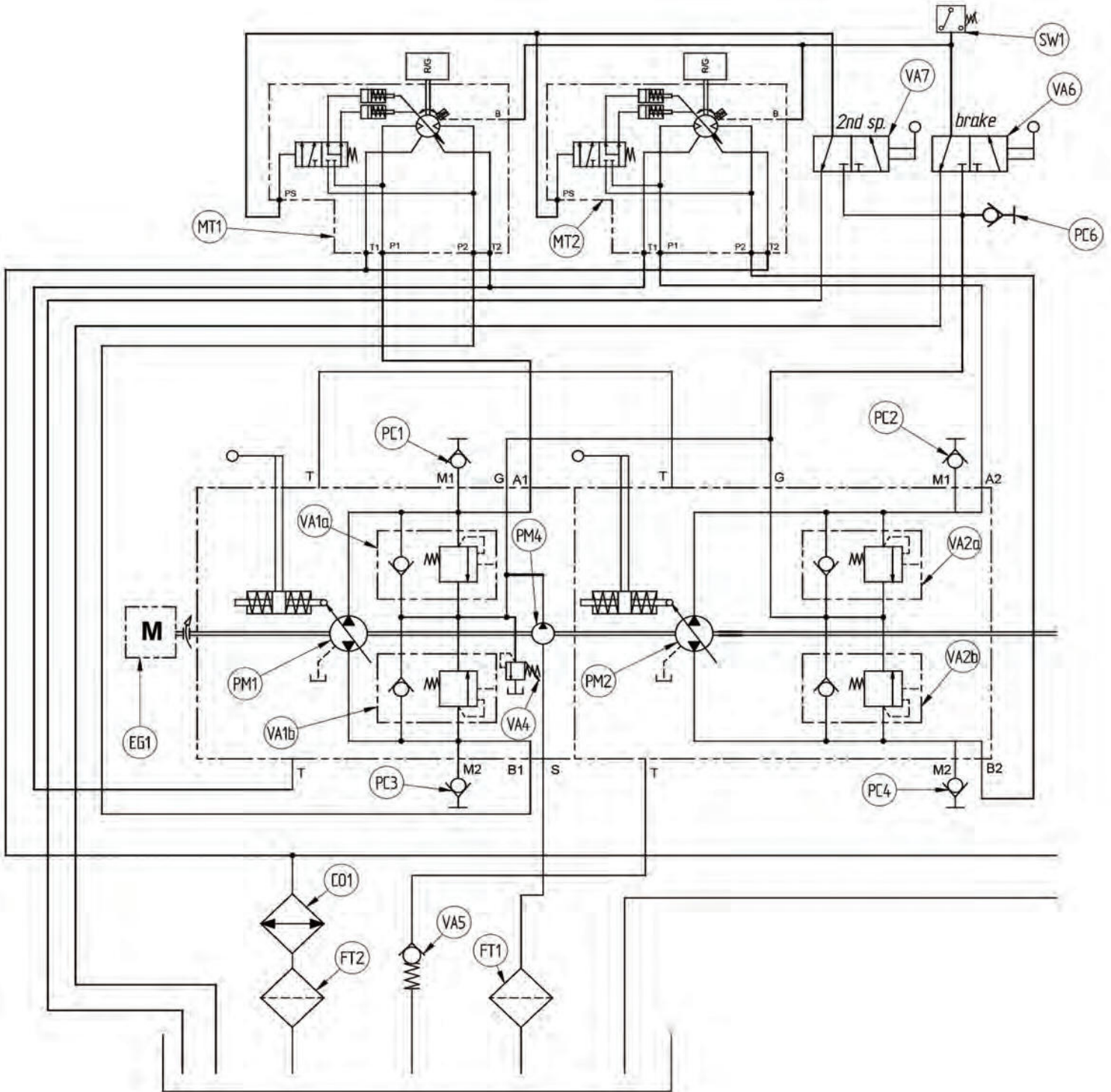

Hydraulic Schematic (cont'd)

Pos.	Part	Technical specifications
CO1	Cooler	
CY1	Cylinder	50x30x480 - dumping
CY2	Cylinder	45x25x168 - swivelling
EG1	Engine	15.5 kw @ 3600 ± 50 rpm
FT1	Suction filter	30 µm
FT2	Return filter	90 µm
MT1	Piston motor	8,7 - 14,72 cc - right track
MT2	Piston motor	8,7 - 14,72 cc - left track
MV1	Main valve	Services
PC1	Pressure check	Right track - forward
PC2	Pressure check	Left track - forward
PC3	Pressure check	Right track - backward
PC4	Pressure check	Left track - backward
PC5	Pressure check	Services
PC6	Pressure check	Charge pump
PM1	Piston pump	8 cc - right track
PM2	Piston pump	8 cc - left track
PM3	Gear pump	2.0 cc - services
PM4	Charge pump	5 cc
VA1a	Relief valve	230±10 bar - right track forward
VA1b	Relief valve	230±10 bar - right track backward
VA2a	Relief valve	230±10 bar - left track forward
VA2b	Relief valve	230±10 bar - left track backward
VA3	Relief valve	160±5 bar - services
VA4	Relief valve	20 ± 22 bar - charge pump
VA5	Check valve	1.5 bar
VA6	Valve	Brake
VA7	Valve	2° gear
VA8	Pilot oper. Check	ratio=6:1 - cracking 3 bar
VA9	One-way restrict.	ø 0,6 mm
VA10	One-way restrict.	ø 0,8 mm
SW1	Pressure switch	Brake

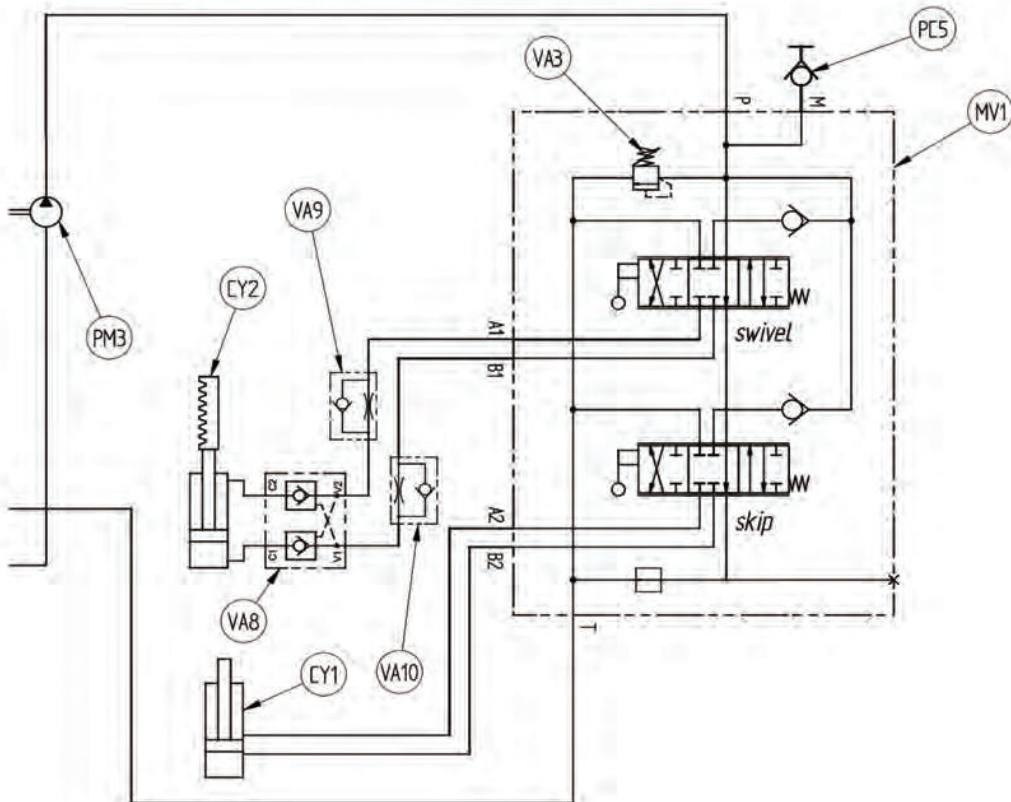

Electrical Schematic

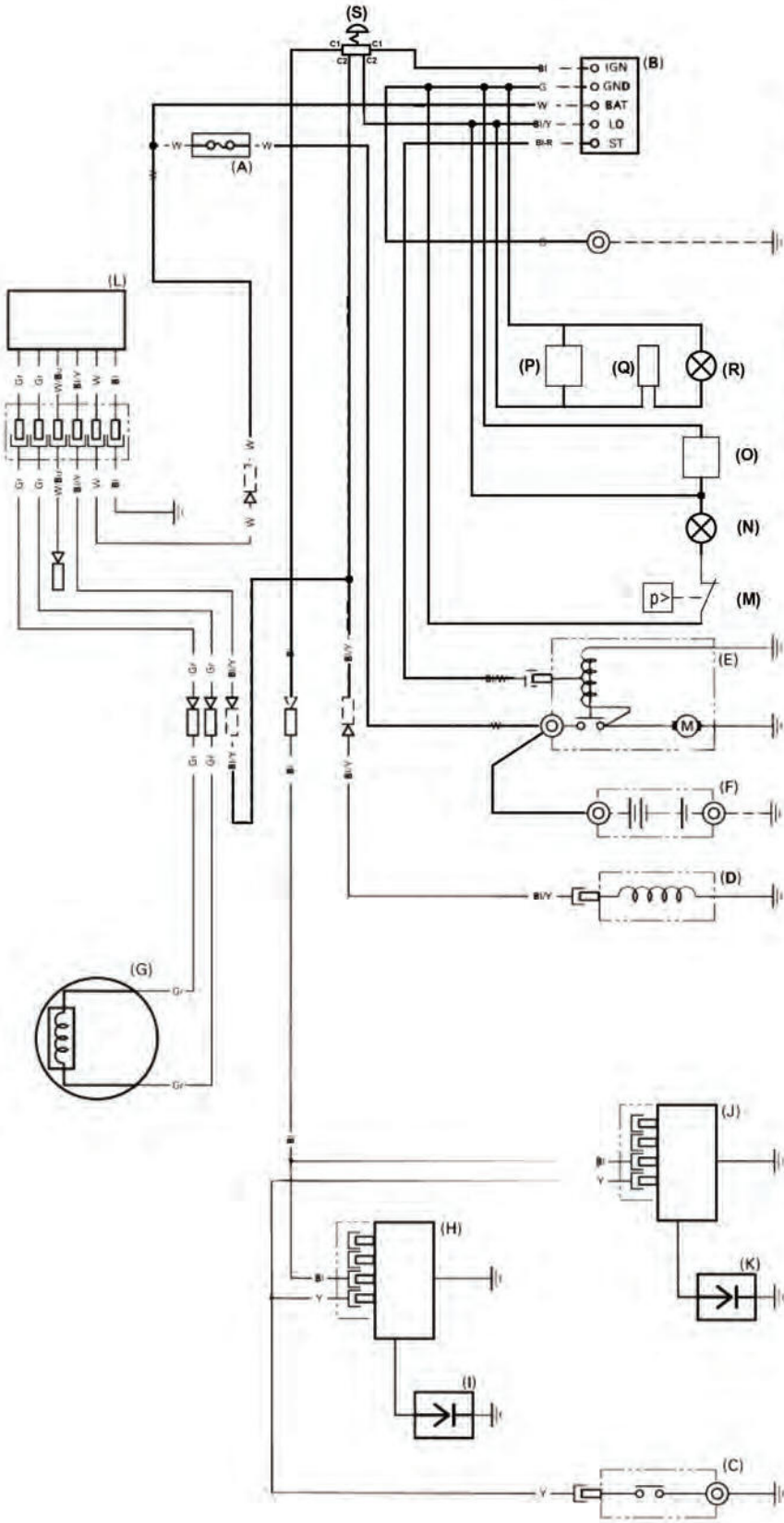

WIRE COLORS

- Bl BLACK
- Y YELLOW
- Bu BLUE
- G GREEN
- R RED
- W WHITE
- Br BROWN
- O BLACK
- Lb LIGHT BLUE
- Lg LIGHT GREEN
- P PINK
- Gr GRAY

NOTE FOR TWO-COLORED WIRES:
 G/Y → YELLOW WITH GREEN DOTS
 G-V → YELLOW WITH A GREEN LINE

	IGN	GND	BAT	LO	ST
OFF					
ON	○	○	○	○	
ST	○	○	○	○	○

ITEM	DESCRIPTION
A	Main fuse
B	Ignition switch
C	Oil level switch
D	Fuel cut solenoid
E	Starter motor
F	Battery
G	Charge coil
H	Ignition coil
I	Spark plug
J	Ignition coil
K	Spark plug
L	Regulator
M	Pressure switch
N	Warning light
O	Hourcounter
P	Fan
Q	Flow control
R	Warning light
S	Emergency stop

***For your own safety and protection from personal injury, carefully read, understand, and observe the safety instructions described in this manual.
Keep this manual or a copy of it with the machine at all times.***

YOUR TOTAL SOURCE FOR CONCRETE EQUIPMENT

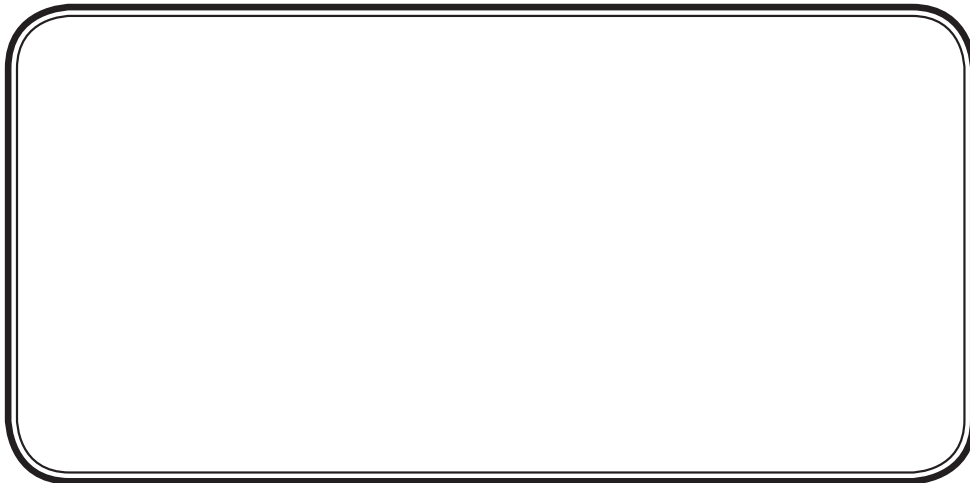

**800-643-0095 or 870-236-7751
FAX: 800-643-0097 or 870-236-3934**

P.O. Box 819 Paragould, Arkansas 72451 USA
www.alleneng.com